

# SN74LVC1T45 Single-Bit Dual-Supply Bus Transceiver With Configurable Voltage Translation and 3-State Outputs

## 1 Features

- ESD protection exceeds JESD 22
  - 2000-V Human-Body Model (A114-A)
  - 200-V Machine Model (A115-A)
  - 1000-V Charged-Device Model (C101)
- Available in the Texas Instruments NanoFree™ package
- Fully configurable dual-rail design allows each port to operate over the full 1.65-V to 5.5-V power-supply range
- $V_{CC}$  isolation feature – if either  $V_{CC}$  input is at GND, both ports are in the high-impedance state
- DIR input circuit referenced to  $V_{CCA}$
- Low power consumption, 4- $\mu$ A maximum  $I_{CC}$
- $\pm 24$ -mA output drive at 3.3 V
- $I_{off}$  supports partial-power-down mode operation
- Maximum data rates
  - 420 Mbps (3.3-V to 5-V translation)
  - 210 Mbps (translate to 3.3 V)
  - 140 Mbps (translate to 2.5 V)
  - 75 Mbps (translate to 1.8 V)
- Latch-up performance exceeds 100 mA per JESD 78, Class II

## 2 Applications

- [Personal electronic](#)
- [Industrial](#)
- [Enterprise](#)
- [Telecom](#)

## Functional Block Diagram

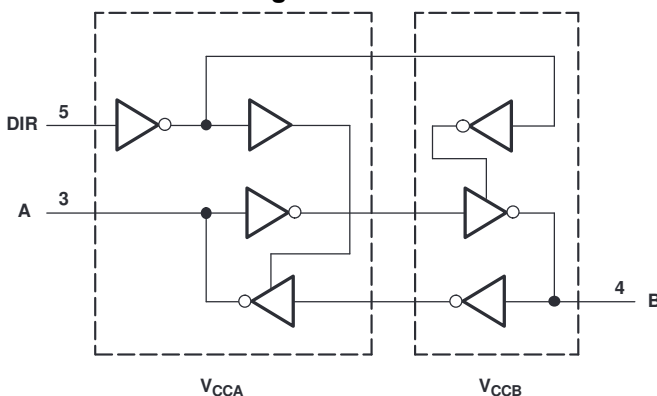

## 3 Description

This single-bit noninverting bus transceiver uses two separate configurable power-supply rails. The A port is designed to track  $V_{CCA}$ .  $V_{CCA}$  accepts any supply voltage from 1.65 V to 5.5 V. The B port is designed to track  $V_{CCB}$ .  $V_{CCB}$  accepts any supply voltage from 1.65 V to 5.5 V. This allows for universal low-voltage bidirectional translation between any of the 1.8-V, 2.5-V, 3.3-V, and 5-V voltage nodes.

The SN74LVC1T45 is designed for asynchronous communication between two data buses. The logic levels of the direction-control (DIR) input activate either the B-port outputs or the A-port outputs. The device transmits data from the A bus to the B bus when the B-port outputs are activated and from the B bus to the A bus when the A-port outputs are activated. The input circuitry is always active on both A and B ports and must have a logic HIGH or LOW level applied to prevent excess  $I_{CC}$  and  $I_{CCZ}$ .

The SN74LVC1T45 is designed so that the DIR input is powered by  $V_{CCA}$ . This device is fully specified for partial-power-down applications using  $I_{off}$ . The  $I_{off}$  circuitry disables the outputs, preventing damaging current backflow through the device when it is powered down. The  $V_{CC}$  isolation feature is designed so that if either  $V_{CC}$  input is at GND, then both ports are in the high-impedance state.

NanoFree package technology is a major breakthrough in IC packaging concepts, using the die as the package.

## Package Information

PART NUMBER	PACKAGE <sup>(1)</sup>	BODY SIZE (NOM)
SN74LVC1T45	DRL (SOT, 6)	1.60 mm × 1.20 mm
	DBV (SOT-23, 6)	2.90 mm × 1.60 mm
	DCK (SC70, 6)	2.00 mm × 1.25 mm
	DPK (USON, 6)	1.60 mm × 1.60 mm
	YZP (DSBGA, 6)	1.39 mm × 0.90 mm

(1) For all available packages, see the orderable addendum at the end of the data sheet.



## Table of Contents

<b>1 Features</b> .....	1	8.2 Functional Block Diagram.....	14
<b>2 Applications</b> .....	1	8.3 Feature Description.....	14
<b>3 Description</b> .....	1	8.4 Device Functional Modes.....	15
<b>4 Revision History</b> .....	2	<b>9 Applications and Implementation</b> .....	16
<b>5 Pin Configuration and Functions</b> .....	3	9.1 Application Information.....	16
<b>6 Specifications</b> .....	5	9.2 Typical Application.....	16
6.1 Absolute Maximum Ratings.....	5	<b>10 Power Supply Recommendations</b> .....	19
6.2 ESD Ratings.....	5	<b>11 Layout</b> .....	19
6.3 Recommended Operating Conditions.....	5	11.1 Layout Guidelines.....	19
6.4 Thermal Information.....	6	11.2 Layout Example.....	19
6.5 Electrical Characteristics.....	7	<b>12 Device and Documentation Support</b> .....	20
6.6 Switching Characteristics ( $V_{CCA} = 1.8\text{ V} \pm 0.15\text{ V}$ ).....	8	12.1 Documentation Support.....	20
6.7 Switching Characteristics ( $V_{CCA} = 2.5\text{ V} \pm 0.2\text{ V}$ ).....	8	12.2 Receiving Notification of Documentation Updates.....	20
6.8 Switching Characteristics ( $V_{CCA} = 3.3\text{ V} \pm 0.3\text{ V}$ ).....	9	12.3 Support Resources.....	20
6.9 Switching Characteristics ( $V_{CCA} = 5\text{ V} \pm 0.5\text{ V}$ ).....	9	12.4 Trademarks.....	20
6.10 Operating Characteristics.....	10	12.5 Electrostatic Discharge Caution.....	20
6.11 Typical Characteristics.....	11	12.6 Glossary.....	20
<b>7 Parameter Measurement Information</b> .....	13	<b>13 Mechanical, Packaging, and Orderable Information</b> .....	20
<b>8 Detailed Description</b> .....	14		
8.1 Overview.....	14		

## 4 Revision History

NOTE: Page numbers for previous revisions may differ from page numbers in the current version.

Changes from Revision L (February 2017) to Revision M (November 2022)	Page
• Updated the numbering format for tables, figures, and cross-references throughout the document.....	1
• Updated the thermals in the <i>Thermal Information</i> section.....	6
• Updated the <i>Switching Characteristics</i> sections: extended some minimum specifications for lower delays .....	8
• Updated the <i>I<sub>off</sub> Supports Partial Power-Down Mode Operation</i> section.....	14
• Added the <i>Balanced High-Drive CMOS Push-Pull Outputs</i> and <i>V<sub>CC</sub> Isolation</i> sections.....	14
• Updated the <i>Power Supply Recommendations</i> section.....	19
Changes from Revision K (December 2014) to Revision L (February 2017)	Page
• Added DPK (USON) package information.....	1
• Added <i>Documentation Support</i> section, <i>Receiving Notification of Documentation Updates</i> section, and <i>Community Resources</i> section.....	1
• Added Junction temperature, T <sub>J</sub> in <i>Absolute Maximum Ratings</i> .....	5
Changes from Revision J (December 2013) to Revision K (December 2014)	Page
• Added <i>Pin Configuration and Functions</i> section, <i>ESD Ratings</i> table, <i>Feature Description</i> section, <i>Device Functional Modes</i> , <i>Application and Implementation</i> section, <i>Power Supply Recommendations</i> section, <i>Layout</i> section, <i>Device and Documentation Support</i> section, and <i>Mechanical, Packaging, and Orderable Information</i> section .....	1
Changes from Revision I (December 2011) to Revision J (December 2013)	Page
• Updated document to new TI data sheet format - no specification changes.....	1
• Removed ordering information.....	1
• Added ESD warning.....	1

## 5 Pin Configuration and Functions

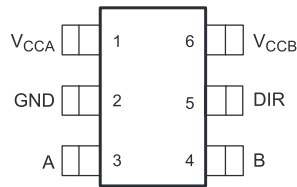

**Figure 5-1. DBV Package, 6-Pin SOT-23 (Top View)**

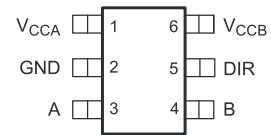

**Figure 5-2. DCK Package, 6-Pin SC70 (Top View)**

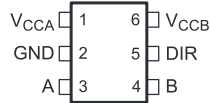

**Figure 5-3. DRL Package, 6-Pin SOT (Top View)**

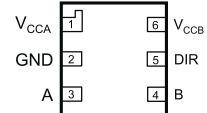
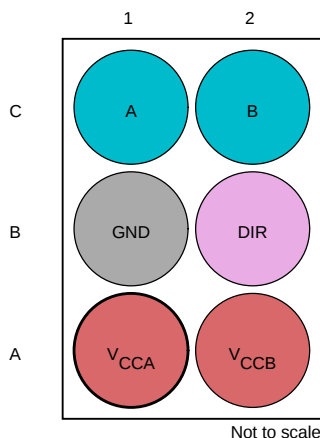

**Figure 5-4. DPK Package, 6-Pin USON (Top View)**

**Table 5-1. Pin Functions**

PIN		TYPE <sup>(1)</sup>	DESCRIPTION
NAME	DBV, DCK, DRL, DPK		
V <sub>CCA</sub>	1	P	SYSTEM-1 supply voltage (1.65 V to 5.5 V)
GND	2	G	Device GND
A	3	I/O	Output level depends on V <sub>CC1</sub> voltage.
B	4	I/O	Input threshold value depends on V <sub>CC2</sub> voltage.
DIR	5	I	GND (low level) determines B-port to A-port direction.
V <sub>CCB</sub>	6	P	SYSTEM-2 supply voltage (1.65 V to 5.5 V)

(1) P = power, G = ground, I/O = input and output, I = input



**Figure 5-5. YZP Package, 6-Pin DSBGA (Bottom View)**

Legend	
Power	Input
Input or Output	Ground

**Table 5-2. Pin Functions**

PIN		TYPE <sup>(1)</sup>	DESCRIPTION
NO.	NAME		
A1	V <sub>CCA</sub>	P	SYSTEM-1 supply voltage (1.65 V to 5.5 V)
A2	V <sub>CCB</sub>	P	SYSTEM-2 supply voltage (1.65 V to 5.5 V)
B1	GND	G	Device GND
B2	DIR	I	GND (low level) determines B-port to A-port direction.
C1	A	I/O	Output level depends on V <sub>CC1</sub> voltage.
C2	B	I/O	Input threshold value depends on V <sub>CC2</sub> voltage.

(1) P = power, G = ground, I/O = input and output, I = input

## 6 Specifications

### 6.1 Absolute Maximum Ratings

over operating free-air temperature range (unless otherwise noted) <sup>(1)</sup>

		MIN	MAX	UNIT	
V <sub>CCA</sub> V <sub>CCB</sub>	Supply voltage	-0.5	6.5	V	
V <sub>I</sub>	Input voltage <sup>(2)</sup>	-0.5	6.5	V	
V <sub>O</sub>	Voltage range applied to any output in the high-impedance or power-off state <sup>(2)</sup>	-0.5	6.5	V	
V <sub>O</sub>	Voltage range applied to any output in the high or low state <sup>(2)</sup> <sup>(3)</sup>	A port	-0.5	V <sub>CCA</sub> + 0.5	V
		B port	-0.5	V <sub>CCB</sub> + 0.5	
I <sub>IK</sub>	Input clamp current		-50	mA	
I <sub>OK</sub>	Output clamp current		-50	mA	
I <sub>O</sub>	Continuous output current		±50	mA	
	Continuous current through V <sub>CC</sub> or GND		±100	mA	
T <sub>J</sub>	Junction temperature		150	°C	
T <sub>stg</sub>	Storage temperature	-65	150	°C	

- (1) Stresses beyond those listed under *Absolute Maximum Ratings* may cause permanent damage to the device. These are stress ratings only, which do not imply functional operation of the device at these or any other conditions beyond those indicated under *Recommended Operating Conditions*. Exposure to absolute-maximum-rated conditions for extended periods may affect device reliability.
- (2) The input and output negative-voltage ratings may be exceeded if the input and output clamp-current ratings are observed.
- (3) The value of V<sub>CC</sub> is provided in the recommended operating conditions table.

### 6.2 ESD Ratings

		VALUE	UNIT
V <sub>(ESD)</sub>	Electrostatic discharge	Human-body model (HBM), per ANSI/ESDA/JEDEC JS-001 <sup>(1)</sup>	±2000
		Charged-device model (CDM), per JEDEC specification JESD22-C101 <sup>(2)</sup>	±1000
		Machine Model	±200

- (1) JEDEC document JEP155 states that 500-V HBM allows safe manufacturing with a standard ESD control process.
- (2) JEDEC document JEP157 states that 250-V CDM allows safe manufacturing with a standard ESD control process.

### 6.3 Recommended Operating Conditions

See (1) (2) (3)

		V <sub>CCI</sub>	V <sub>CCO</sub>	MIN	MAX	UNIT
V <sub>CCA</sub> V <sub>CCB</sub>	Supply voltage			1.65	5.5	V
				1.65	5.5	
V <sub>IH</sub>	High-level input voltage	Data inputs <sup>(4)</sup>	1.65 to 1.95 V	V <sub>CCI</sub> × 0.65		V
			2.3 to 2.7 V	1.7		
			3 to 3.6 V	2		
			4.5 to 5.5 V	V <sub>CCI</sub> × 0.7		
V <sub>IL</sub>	Low-level input voltage	Data inputs <sup>(4)</sup>	1.65 to 1.95 V	V <sub>CCI</sub> × 0.35		V
			2.3 to 2.7 V	0.7		
			3 to 3.6 V	0.8		
			4.5 to 5.5 V	V <sub>CCI</sub> × 0.3		
V <sub>IH</sub>	High-level input voltage	DIR (referenced to V <sub>CCA</sub> ) <sup>(5)</sup>	1.65 to 1.95 V	V <sub>CCA</sub> × 0.65		V
			2.3 to 2.7 V	1.7		
			3 to 3.6 V	2		
			4.5 to 5.5 V	V <sub>CCA</sub> × 0.7		

### 6.3 Recommended Operating Conditions (continued)

See (1) (2) (3)

		$V_{CCI}$	$V_{CCO}$	MIN	MAX	UNIT
$V_{IL}$	Low-level input voltage	DIR (referenced to $V_{CCA}$ ) <sup>(5)</sup>	1.65 to 1.95 V		$V_{CCA} \times 0.35$	V
			2.3 to 2.7 V		0.7	
			3 to 3.6 V		0.8	
			4.5 to 5.5 V		$V_{CCA} \times 0.3$	
$V_I$	Input voltage			0	5.5	V
$V_O$	Output voltage			0	$V_{CCO}$	V
$I_{OH}$	High-level output current		1.65 to 1.95 V		-4	mA
			2.3 to 2.7 V		-8	
			3 to 3.6 V		-24	
			4.5 to 5.5 V		-32	
$I_{OL}$	Low-level output current		1.65 to 1.95 V		4	mA
			2.3 to 2.7 V		8	
			3 to 3.6 V		24	
			4.5 to 5.5 V		32	
$\Delta t/\Delta v$	Input transition rise or fall rate	Data inputs	1.65 to 1.95 V		20	ns/V
			2.3 to 2.7 V		20	
			3 to 3.6 V		10	
			4.5 to 5.5 V		5	
		Control inputs	1.65 to 5.5 V		5	
$T_A$	Operating free-air temperature			-40	85	°C

- (1)  $V_{CCI}$  is the  $V_{CC}$  associated with the input port.
- (2)  $V_{CCO}$  is the  $V_{CC}$  associated with the output port.
- (3) All unused data inputs of the device must be held at  $V_{CCI}$  or GND to ensure proper device operation. See the TI application report, [Implications of Slow or Floating CMOS Inputs](#), SCBA004.
- (4) For  $V_{CCI}$  values not specified in the data sheet,  $V_{IH\ min} = V_{CCI} \times 0.7\ V$ ,  $V_{IL\ max} = V_{CCI} \times 0.3\ V$ .
- (5) For  $V_{CCI}$  values not specified in the data sheet,  $V_{IH\ min} = V_{CCA} \times 0.7\ V$ ,  $V_{IL\ max} = V_{CCA} \times 0.3\ V$ .

### 6.4 Thermal Information

THERMAL METRIC <sup>(1)</sup>	SN74LVC1T45					UNIT	
	DBV (SOT-23)	DCK (SC70)	DPK (USON)	DRL (SOT)	YZP (DSBGA)		
	6 PINS						
$R_{\theta JA}$	Junction-to-ambient thermal resistance	215.1	210.9	278.3	223.7	131.0	°C/W
$R_{\theta JC(top)}$	Junction-to-case (top) thermal resistance	136.5	139.2	133.4	88.7	1.3	°C/W
$R_{\theta JB}$	Junction-to-board thermal resistance	96.6	72	174.1	58.4	22.6	°C/W
$\Psi_{JT}$	Junction-to-top characterization parameter	71.5	54.9	23.4	5.9	5.2	°C/W
$\Psi_{JB}$	Junction-to-board characterization parameter	96.3	71.7	173.5	58.1	22.6	°C/W

- (1) For more information about traditional and new thermal metrics, see the [Semiconductor and IC Package Thermal Metrics](#) application report.

## 6.5 Electrical Characteristics

over recommended operating free-air temperature range,  $T_A = -40$  to  $+85^\circ\text{C}$  (unless otherwise noted)<sup>(1) (2)</sup>

PARAMETER		TEST CONDITIONS	$V_{CCA}$	$V_{CCB}$	MIN	TYP	MAX	UNIT
$V_{OH}$		$V_I = V_{IH}$	1.65 to 4.5 V	1.65 to 4.5 V	$V_{CCO} - 0.1$		V	
			1.65 V	1.65 V	1.2			
			2.3 V	2.3 V	1.9			
			3 V	3 V	2.4			
			4.5 V	4.5 V	3.8			
$V_{OL}$		$V_I = V_{IL}$	1.65 to 4.5 V	1.65 to 4.5 V	0.1		V	
			1.65 V	1.65 V	0.45			
			2.3 V	2.3 V	0.3			
			3 V	3 V	0.55			
			4.5 V	4.5 V	0.55			
$I_I$	DIR	$V_I = V_{CCA}$ or GND	1.65 to 5.5 V	1.65 to 5.5 V	$T_A = 25^\circ\text{C}$		$\pm 1$	$\mu\text{A}$
					$T_A = -40$ to $+85^\circ\text{C}$		$\pm 2$	
$I_{off}$	A port	$V_I$ or $V_O = 0$ to 5.5 V	0 V	0 to 5.5 V	$T_A = 25^\circ\text{C}$		$\pm 1$	$\mu\text{A}$
					$T_A = -40$ to $+85^\circ\text{C}$		$\pm 2$	
	B port		$T_A = 25^\circ\text{C}$		$\pm 1$			
			$T_A = -40$ to $+85^\circ\text{C}$		$\pm 2$			
$I_{OZ}$	A or B port	$V_O = V_{CCO}$ or GND	1.65 to 5.5 V	1.65 to 5.5 V	$T_A = 25^\circ\text{C}$		$\pm 1$	$\mu\text{A}$
					$T_A = -40$ to $+85^\circ\text{C}$		$\pm 2$	
$I_{CCA}$		$V_I = V_{CCI}$ or GND, $I_O = 0$	1.65 to 5.5 V	1.65 to 5.5 V	3		$\mu\text{A}$	
			5.5 V	0 V	2			
			0 V	5.5 V	-2			
$I_{CCB}$		$V_I = V_{CCI}$ or GND, $I_O = 0$	1.65 to 5.5 V	1.65 to 5.5 V	3		$\mu\text{A}$	
			5.5 V	0 V	-2			
			0 V	5.5 V	2			
$I_{CCA} + I_{CCB}$ (see Table 8-1)		$V_I = V_{CCI}$ or GND, $I_O = 0$	1.65 to 5.5 V	1.65 to 5.5 V	4		$\mu\text{A}$	
$\Delta I_{CCA}$	A port	A port at $V_{CCA} - 0.6$ V, DIR at $V_{CCA}$ , B port = open	3 to 5.5 V	3 to 5.5 V	50		$\mu\text{A}$	
	DIR	DIR at $V_{CCA} - 0.6$ V, B port = open, A port at $V_{CCA}$ or GND			50			
$\Delta I_{CCB}$	B port	B port at $V_{CCB} - 0.6$ V, DIR at GND, A port = open	3 to 5.5 V	3 to 5.5 V	50		$\mu\text{A}$	
$C_i$	DIR	$V_I = V_{CCA}$ or GND	3.3 V	3.3 V	$T_A = 25^\circ\text{C}$	2.5	pF	
$C_{io}$	A or B port	$V_O = V_{CCA/B}$ or GND	3.3 V	3.3 V	$T_A = 25^\circ\text{C}$	6	pF	

(1)  $V_{CCO}$  is the  $V_{CC}$  associated with the output port.

(2)  $V_{CCI}$  is the  $V_{CC}$  associated with the input port.

## 6.6 Switching Characteristics ( $V_{CCA} = 1.8 \text{ V} \pm 0.15 \text{ V}$ )

over recommended operating free-air temperature range,  $V_{CCA} = 1.8 \text{ V} \pm 0.15 \text{ V}$  (see [Figure 7-1](#))

PARAMETER	FROM (INPUT)	TO (OUTPUT)	$V_{CCB} = 1.8 \text{ V} \pm 0.15 \text{ V}$		$V_{CCB} = 2.5 \text{ V} \pm 0.2 \text{ V}$		$V_{CCB} = 3.3 \text{ V} \pm 0.3 \text{ V}$		$V_{CCB} = 5 \text{ V} \pm 0.5 \text{ V}$		UNIT
			MIN	MAX	MIN	MAX	MIN	MAX	MIN	MAX	
$t_{PLH}$	A	B	3	17.7	2.2	10.3	1.7	8.3	1.4	7.2	ns
$t_{PHL}$			2.8	14.3	2.2	8.5	1.8	7.1	1.7	7	
$t_{PLH}$	B	A	3	17.7	2.3	16	2.1	15.5	1.9	15.1	ns
$t_{PHL}$			2.8	14.3	2.1	12.9	2	12.6	1.8	12.2	
$t_{PHZ}$	DIR	A	5.2	19.4	4.8	18.5	4.7	18.4	5.1	17.1	ns
$t_{PLZ}$			2.3	10.5	2.1	10.5	2.4	10.7	3.1	10.9	
$t_{PHZ}$	DIR	B	5.2	21.9	4.9	11.5	4.6	10.3	2.8	8.2	ns
$t_{PLZ}$			4.2	16	3.7	9.2	3.3	8.4	2.4	6.4	
$t_{PZH}^{(1)}$	DIR	A		33.7		25.2		23.9		21.5	ns
$t_{PZL}^{(1)}$				36.2		24.4		22.9		20.4	
$t_{PZH}^{(1)}$	DIR	B		28.2		20.8		19		18.1	ns
$t_{PZL}^{(1)}$				33.7		27		25.5		24.1	

(1) The enable time is a calculated value, derived using the formula shown in the [Section 9.2.2.2.1](#) section.

## 6.7 Switching Characteristics ( $V_{CCA} = 2.5 \text{ V} \pm 0.2 \text{ V}$ )

over recommended operating free-air temperature range,  $V_{CCA} = 2.5 \text{ V} \pm 0.2 \text{ V}$  (see [Figure 7-1](#))

PARAMETER	FROM (INPUT)	TO (OUTPUT)	$V_{CCB} = 1.8 \text{ V} \pm 0.15 \text{ V}$		$V_{CCB} = 2.5 \text{ V} \pm 0.2 \text{ V}$		$V_{CCB} = 3.3 \text{ V} \pm 0.3 \text{ V}$		$V_{CCB} = 5 \text{ V} \pm 0.5 \text{ V}$		UNIT
			MIN	MAX	MIN	MAX	MIN	MAX	MIN	MAX	
$t_{PLH}$	A	B	2.3	16	1.5	8.5	1.3	6.4	1.1	5.1	ns
$t_{PHL}$			2.1	12.9	1.4	7.5	1.3	5.4	0.9	4.6	
$t_{PLH}$	B	A	2.2	10.3	1.5	8.5	1.4	8	1	7.5	ns
$t_{PHL}$			2.2	8.5	1.4	7.5	1.3	7	0.9	6.2	
$t_{PHZ}$	DIR	A	3	8.1	3.1	8.1	2.8	8.1	3.2	8.1	ns
$t_{PLZ}$			1.3	5.9	1.3	5.9	1.3	5.9	1	5.8	
$t_{PHZ}$	DIR	B	5.2	23.7	4.1	11.4	3.9	10.2	2.4	7.1	ns
$t_{PLZ}$			3.9	18.9	3.2	9.6	2.8	8.4	1.8	5.3	
$t_{PZH}^{(1)}$	DIR	A		29.2		18.1		16.4		12.8	ns
$t_{PZL}^{(1)}$				32.2		18.9		17.2		13.3	
$t_{PZH}^{(1)}$	DIR	B		21.9		14.4		12.3		10.9	ns
$t_{PZL}^{(1)}$				21		15.6		13.5		12.7	

(1) The enable time is a calculated value, derived using the formula shown in the [Section 9.2.2.2.1](#) section.



## 6.8 Switching Characteristics ( $V_{CCA} = 3.3 \text{ V} \pm 0.3 \text{ V}$ )

over recommended operating free-air temperature range,  $V_{CCA} = 3.3 \text{ V} \pm 0.3 \text{ V}$  (see [Figure 7-1](#))

PARAMETER	FROM (INPUT)	TO (OUTPUT)	$V_{CCB} = 1.8 \text{ V} \pm 0.15 \text{ V}$		$V_{CCB} = 2.5 \text{ V} \pm 0.2 \text{ V}$		$V_{CCB} = 3.3 \text{ V} \pm 0.3 \text{ V}$		$V_{CCB} = 5 \text{ V} \pm 0.5 \text{ V}$		UNIT
			MIN	MAX	MIN	MAX	MIN	MAX	MIN	MAX	
$t_{PLH}$	A	B	2.1	15.5	1.4	8	0.7	5.8	0.7	4.4	ns
$t_{PHL}$			2	12.6	1.3	7	0.8	5	0.7	4	
$t_{PLH}$	B	A	1.7	8.3	1.3	6.4	0.7	5.8	0.6	5.4	ns
$t_{PHL}$			1.8	7.1	1.3	5.4	0.8	5	0.7	4.5	
$t_{PHZ}$	DIR	A	2.9	7.3	3	7.3	2.8	7.3	3.4	7.3	ns
$t_{PLZ}$			1.8	5.6	1.6	5.6	2.2	5.7	2.2	5.7	
$t_{PHZ}$	DIR	B	5.4	20.5	3.9	10.1	2.9	8.8	2.4	6.8	ns
$t_{PLZ}$			3.3	14.5	2.9	7.8	2.4	7.1	1.7	4.9	
$t_{PZH}^{(1)}$	DIR	A		22.8		14.2		12.9		10.3	ns
$t_{PZL}^{(1)}$				27.6		15.5		13.8		11.3	
$t_{PZH}^{(1)}$	DIR	B		21.1		13.6		11.5		10.1	ns
$t_{PZL}^{(1)}$				19.9		14.3		12.3		11.3	

(1) The enable time is a calculated value, derived using the formula shown in the [Section 9.2.2.2.1](#) section.

## 6.9 Switching Characteristics ( $V_{CCA} = 5 \text{ V} \pm 0.5 \text{ V}$ )

over recommended operating free-air temperature range,  $V_{CCA} = 5 \text{ V} \pm 0.5 \text{ V}$  (see [Figure 7-1](#))

PARAMETER	FROM (INPUT)	TO (OUTPUT)	$V_{CCB} = 1.8 \text{ V} \pm 0.15 \text{ V}$		$V_{CCB} = 2.5 \text{ V} \pm 0.2 \text{ V}$		$V_{CCB} = 3.3 \text{ V} \pm 0.3 \text{ V}$		$V_{CCB} = 5 \text{ V} \pm 0.5 \text{ V}$		UNIT
			MIN	MAX	MIN	MAX	MIN	MAX	MIN	MAX	
$t_{PLH}$	A	B	1.9	15.1	1	7.5	0.6	5.4	0.5	3.9	ns
$t_{PHL}$			1.8	12.2	0.9	6.2	0.7	4.5	0.5	3.5	
$t_{PLH}$	B	A	1.4	7.2	1	5.1	0.7	4.4	0.5	3.9	ns
$t_{PHL}$			1.7	7	0.9	4.6	0.7	4	0.5	3.5	
$t_{PHZ}$	DIR	A	2.1	5.4	2.2	5.4	2.2	5.5	2.2	5.4	ns
$t_{PLZ}$			0.9	3.8	1	3.8	0.7	3.7	0.7	3.7	
$t_{PHZ}$	DIR	B	4.8	20.2	2.5	9.8	1	8.5	2.5	6.5	ns
$t_{PLZ}$			3.2	14.8	2.5	7.4	2.5	7	1.6	4.5	
$t_{PZH}^{(1)}$	DIR	A		22		12.5		11.4		8.4	ns
$t_{PZL}^{(1)}$				27.2		14.4		12.5		10	
$t_{PZH}^{(1)}$	DIR	B		18.9		11.3		9.1		7.6	ns
$t_{PZL}^{(1)}$				17.6		11.6		10		8.6	

(1) The enable time is a calculated value, derived using the formula shown in the [Section 9.2.2.2.1](#) section.

## 6.10 Operating Characteristics

$T_A = 25^\circ\text{C}$

PARAMETER		TEST CONDITIONS	$V_{CCA} =$ $V_{CCB} = 1.8\text{ V}$	$V_{CCA} =$ $V_{CCB} = 2.5\text{ V}$	$V_{CCA} =$ $V_{CCB} = 3.3\text{ V}$	$V_{CCA} =$ $V_{CCB} = 5\text{ V}$	UNIT
			TYP	TYP	TYP	TYP	
$C_{pdA}$ <sup>(1)</sup>	A-port input, B-port output	$C_L = 0\text{ pF}$ , $f = 10\text{ MHz}$ , $t_r = t_f = 1\text{ ns}$	3	4	4	4	pF
	B-port input, A-port output		18	19	20	21	
$C_{pdB}$ <sup>(1)</sup>	A-port input, B-port output	$C_L = 0\text{ pF}$ , $f = 10\text{ MHz}$ , $t_r = t_f = 1\text{ ns}$	18	19	20	21	pF
	B-port input, A-port output		3	4	4	4	

(1) Power dissipation capacitance per transceiver

### 6.11 Typical Characteristics

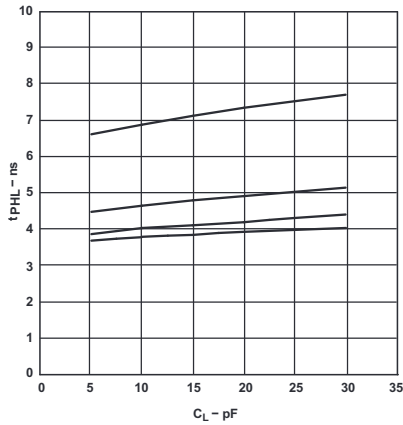

$T_A = 25^\circ\text{C}, V_{CCA} = 1.8\text{ V}$

**Figure 6-1. Typical Propagation Delay (A to B) vs Load Capacitance**

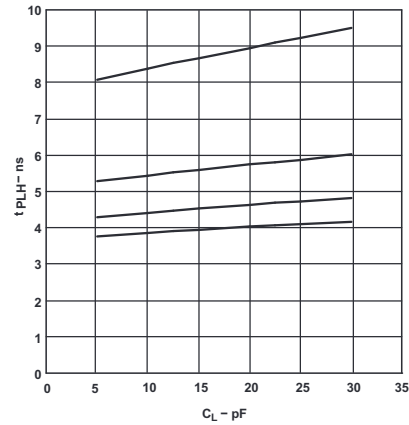

$T_A = 25^\circ\text{C}, V_{CCA} = 1.8\text{ V}$

**Figure 6-2. Typical Propagation Delay (B to A) vs Load Capacitance**

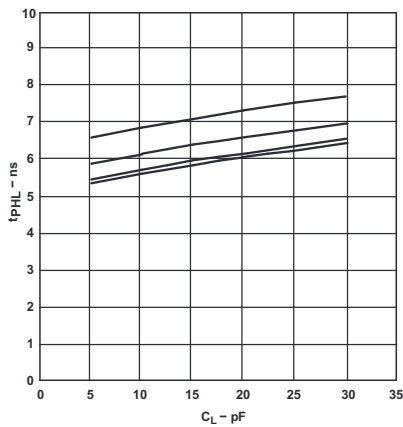

$T_A = 25^\circ\text{C}, V_{CCA} = 2.5\text{ V}$

**Figure 6-3. Typical Propagation Delay (A to B) vs Load Capacitance**

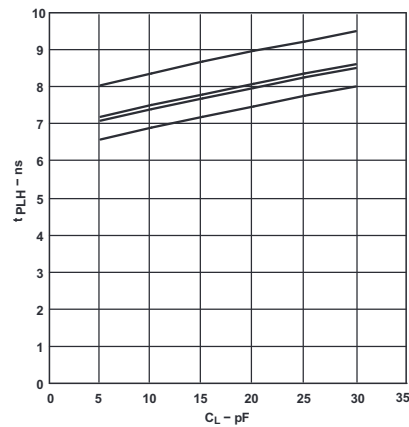

$T_A = 25^\circ\text{C}, V_{CCA} = 2.5\text{ V}$

**Figure 6-4. Typical Propagation Delay (B to A) vs Load Capacitance**

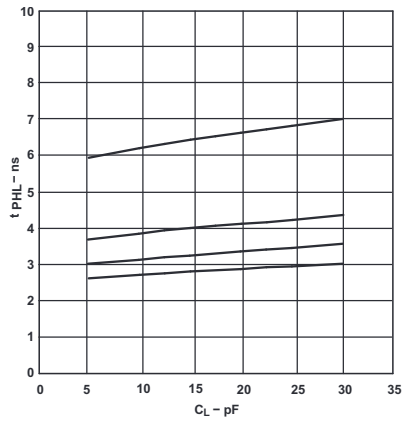

$T_A = 25^\circ\text{C}, V_{CCA} = 3.3\text{ V}$

**Figure 6-5. Typical Propagation Delay (A to B) vs Load Capacitance**

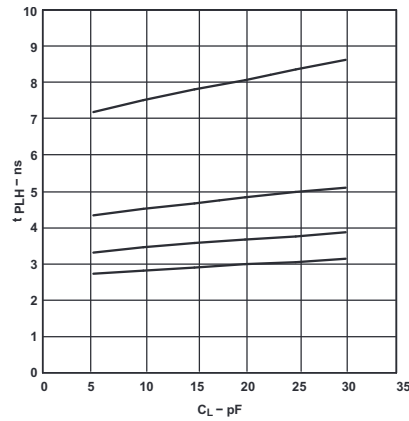

$T_A = 25^\circ\text{C}, V_{CCA} = 3.3\text{ V}$

**Figure 6-6. Typical Propagation Delay (B to A) vs Load Capacitance**

**6.11 Typical Characteristics (continued)**

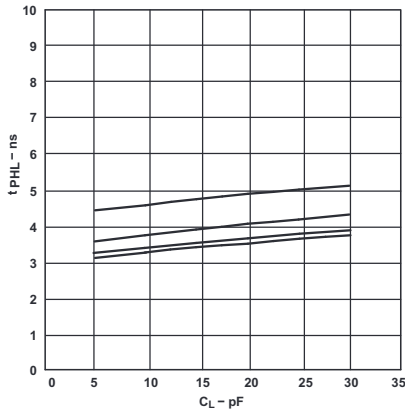

$T_A = 25^\circ\text{C}, V_{CC} = 5\text{ V}$

**Figure 6-7. Typical Propagation Delay (A to B) vs Load Capacitance**

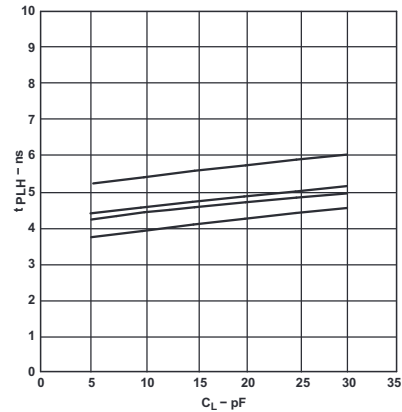

$T_A = 25^\circ\text{C}, V_{CC} = 5\text{ V}$

**Figure 6-8. Typical Propagation Delay (B to A) vs Load Capacitance**

## 7 Parameter Measurement Information

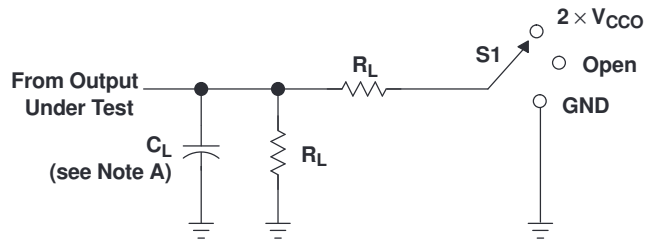

LOAD CIRCUIT

$V_{CCO}$	$C_L$	$R_L$	$V_{TP}$
1.8 V ± 0.15 V	15 pF	2 kΩ	0.15 V
2.5 V ± 0.2 V	15 pF	2 kΩ	0.15 V
3.3 V ± 0.3 V	15 pF	2 kΩ	0.3 V
5 V ± 0.5 V	15 pF	2 kΩ	0.3 V

TEST	S1
$t_{pd}$	Open
$t_{PLZ}/t_{PZL}$	$2 \times V_{CCO}$
$t_{PHZ}/t_{PZH}$	GND

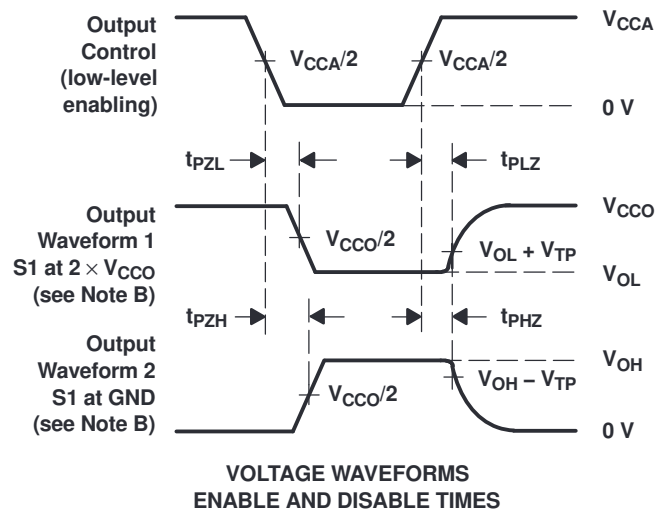
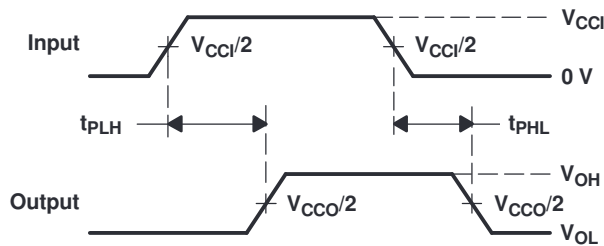
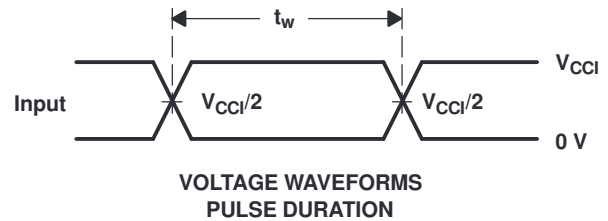

- NOTES:
- A.  $C_L$  includes probe and jig capacitance.
  - B. Waveform 1 is for an output with internal conditions such that the output is low, except when disabled by the output control. Waveform 2 is for an output with internal conditions such that the output is high, except when disabled by the output control.
  - C. All input pulses are supplied by generators having the following characteristics: PRR ≤ 10 MHz,  $Z_O = 50 \Omega$ ,  $dv/dt \geq 1$  V/ns.
  - D. The outputs are measured one at a time, with one transition per measurement.
  - E.  $t_{PLZ}$  and  $t_{PHZ}$  are the same as  $t_{dis}$ .
  - F.  $t_{PZL}$  and  $t_{PZH}$  are the same as  $t_{en}$ .
  - G.  $t_{PLH}$  and  $t_{PHL}$  are the same as  $t_{pd}$ .
  - H.  $V_{CCI}$  is the  $V_{CC}$  associated with the input port.
  - I.  $V_{CCO}$  is the  $V_{CC}$  associated with the output port.
  - J. All parameters and waveforms are not applicable to all devices.

Figure 7-1. Load Circuit and Voltage Waveforms

## 8 Detailed Description

### 8.1 Overview

The SN74LVC1T45 is a single-bit, dual-supply, noninverting voltage level transceiver. Pin A and the direction control pin (DIR) are supported by  $V_{CCA}$  and pin B is supported by  $V_{CCB}$ . The A port is able to accept I/O voltages ranging from 1.65 V to 5.5 V, while the B port can accept I/O voltages from 1.65 V to 5.5 V. The high on the DIR allows data transmissions from A to B and a low on the DIR allows data transmissions from B to A.

### 8.2 Functional Block Diagram

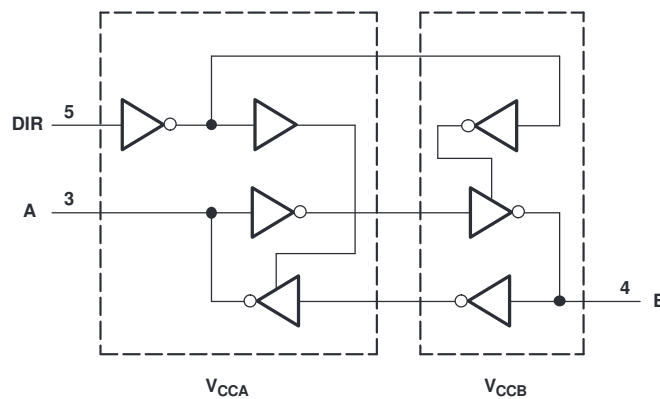

Figure 8-1. Logic Diagram (Positive Logic)

### 8.3 Feature Description

#### 8.3.1 Fully Configurable Dual-Rail Design Allows Each Port to Operate Over the Full 1.65-V to 5.5-V Power-Supply Range

Both  $V_{CCA}$  and  $V_{CCB}$  can be supplied at any voltage between 1.65 V and 5.5 V, making the device suitable for translating between any of the voltage nodes (1.8-V, 2.5-V, 3.3-V, and 5-V).

#### 8.3.2 Support High Speed Translation

The SN74LVC1T45 device supports high data rate applications. The translated signal data rate can be up to 420 Mbps when the signal is translated from 3.3 V to 5 V.

#### 8.3.3 $I_{off}$ Supports Partial Power-Down Mode Operation

The inputs and outputs for this device enter a high-impedance state when the device is powered down, inhibiting current backflow into the device. The maximum leakage into or out of any input or output pin on the device is specified by  $I_{off}$  in the [Electrical Characteristics](#).

#### 8.3.4 Balanced High-Drive CMOS Push-Pull Outputs

A balanced output allows the device to sink and source similar currents. The high drive capability of this device creates fast edges into light loads so impedance matching and load conditions should be considered to prevent ringing. Additionally, the outputs of this device are capable of driving larger currents than the device can sustain without being damaged. Two outputs can be connected together for a stronger output drive strength. The electrical and thermal limits defined in the [Absolute Maximum Ratings](#) must be followed at all times.

#### 8.3.5 $V_{cc}$ Isolation

The I/O's of both ports will enter a high-impedance state when either of the supplies are at GND, while the other supply is still connected to the device. The maximum leakage into or out of any input or output pin on the device is specified by  $I_{off}$  in the [Electrical Characteristics](#).

## 8.4 Device Functional Modes

**Table 8-1. Function Table<sup>(1)</sup>**

INPUT DIR	OPERATION
L	B data to A bus
H	A data to B bus

(1) Input circuits of the data I/Os always are active.

## 9 Applications and Implementation

### Note

Information in the following applications sections is not part of the TI component specification, and TI does not warrant its accuracy or completeness. TI's customers are responsible for determining suitability of components for their purposes, as well as validating and testing their design implementation to confirm system functionality.

### 9.1 Application Information

The SN74LVC1T45 device can be used in level-translation applications for interfacing devices or systems operating at different interface voltages with one another. The maximum data rate can be up to 420 Mbps when device translates signals from 3.3 V to 5 V.

### 9.2 Typical Application

#### 9.2.1 Unidirectional Logic Level-Shifting Application

Figure 9-1 shows an example of the SN74LVC1T45 being used in a unidirectional logic level-shifting application.

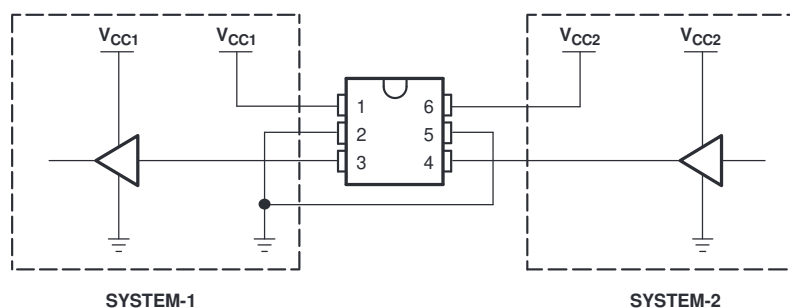

Figure 9-1. Unidirectional Logic Level-Shifting Application

##### 9.2.1.1 Design Requirements

For this design example, use the parameters listed in Table 9-1.

Table 9-1. Design Parameters

DESIGN PARAMETER	EXAMPLE VALUE
Input voltage range	1.65 V to 5.5 V
Output voltage range	1.65 V to 5.5 V

##### 9.2.1.2 Detailed Design Procedure

To begin the design process, determine the following:

- Input voltage range
  - Use the supply voltage of the device that is driving the SN74LVC1T45 device to determine the input voltage range. For a valid logic high the value must exceed the  $V_{IH}$  of the input port. For a valid logic low the value must be less than the  $V_{IL}$  of the input port.
- Output voltage range
  - Use the supply voltage of the device that the SN74LVC1T45 device is driving to determine the output voltage range.



### 9.2.1.3 Application Curve

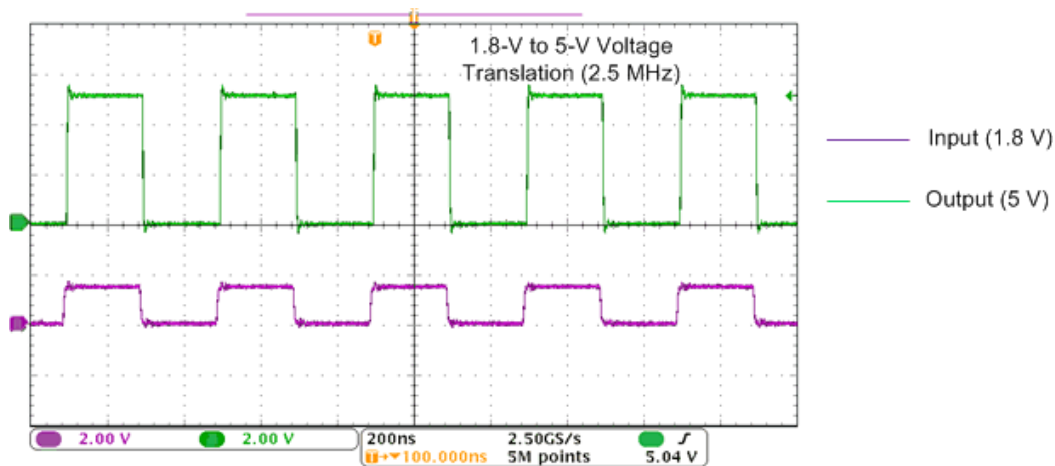

Figure 9-2. Translation Up (1.8 V to 5 V) at 2.5 MHz

### 9.2.2 Bidirectional Logic Level-Shifting Application

Figure 9-3 shows the SN74LVC1T45 being used in a bidirectional logic level-shifting application. Because the SN74LVC1T45 does not have an output-enable ( $\overline{OE}$ ) pin, the system designer should take precautions to avoid bus contention between SYSTEM-1 and SYSTEM-2 when changing directions.

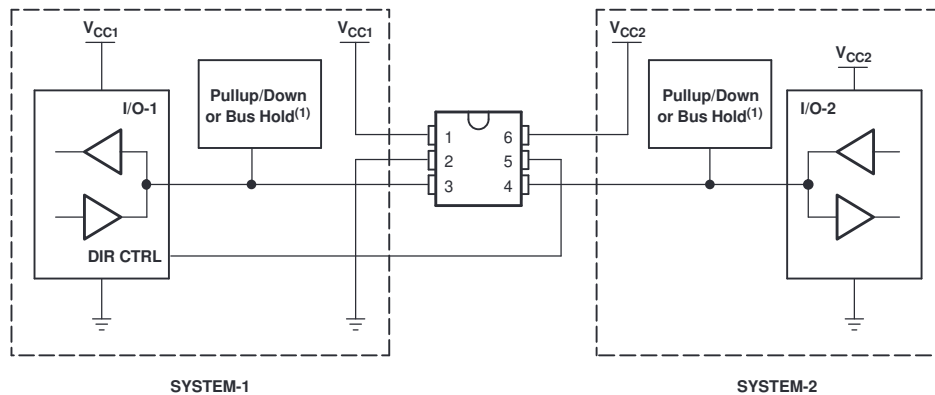

Figure 9-3. Bidirectional Logic Level-Shifting Application

#### 9.2.2.1 Design Requirements

See Section 9.2.1.1.

#### 9.2.2.2 Detailed Design Procedure

Table 9-2 shows data transmission from SYSTEM-1 to SYSTEM-2 and then from SYSTEM-2 to SYSTEM-1.

Table 9-2. SYSTEM-1 and SYSTEM-2 Data Transmission

STATE	DIR CTRL	I/O-1	I/O-2	DESCRIPTION
1	H	Out	In	SYSTEM-1 data to SYSTEM-2
2	H	Hi-Z	Hi-Z	SYSTEM-2 is getting ready to send data to SYSTEM-1. I/O-1 and I/O-2 are disabled. The bus-line state depends on pullup or pulldown. <sup>(1)</sup>
3	L	Hi-Z	Hi-Z	DIR bit is flipped. I/O-1 and I/O-2 still are disabled. The bus-line state depends on pullup or pulldown. <sup>(1)</sup>
4	L	In	Out	SYSTEM-2 data to SYSTEM-1

(1) SYSTEM-1 and SYSTEM-2 must use the same conditions, that is, both pullup or both pulldown.

**SN74LVC1T45**

SCES515M – DECEMBER 2003 – REVISED NOVEMBER 2022

**9.2.2.2.1 Enable Times**

Calculate the enable times for the SN74LVC1T45 using the following formulas:

- $t_{PZH} \text{ (DIR to A)} = t_{PLZ} \text{ (DIR to B)} + t_{PLH} \text{ (B to A)}$
- $t_{PZL} \text{ (DIR to A)} = t_{PHZ} \text{ (DIR to B)} + t_{PHL} \text{ (B to A)}$
- $t_{PZH} \text{ (DIR to B)} = t_{PLZ} \text{ (DIR to A)} + t_{PLH} \text{ (A to B)}$
- $t_{PZL} \text{ (DIR to B)} = t_{PHZ} \text{ (DIR to A)} + t_{PHL} \text{ (A to B)}$

In a bidirectional application, these enable times provide the maximum delay from the time the DIR bit is switched until an output is expected. For example, if the SN74LVC1T45 initially is transmitting from A to B, then the DIR bit is switched; the B port of the device must be disabled before presenting it with an input. After the B port has been disabled, an input signal applied to it appears on the corresponding A port after the specified propagation delay.

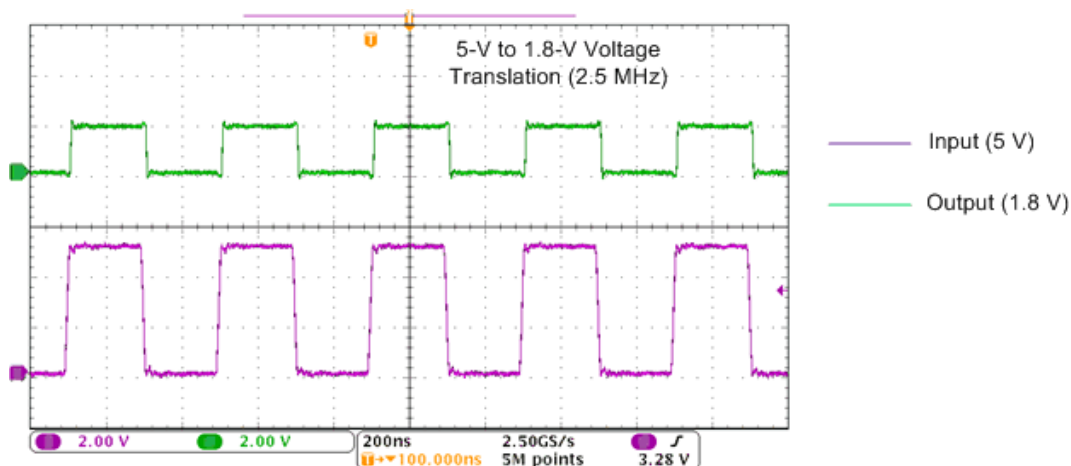
**9.2.2.3 Application Curve**

**Figure 9-4. Translation Down (5V to 1.8 V) at 2.5 MHz**

## 10 Power Supply Recommendations

The SN74LVC1T45 device uses two separate configurable power-supply rails,  $V_{CCA}$  and  $V_{CCB}$ .  $V_{CCA}$  accepts any supply voltage from 1.65 V to 5.5 V and  $V_{CCB}$  accepts any supply voltage from 1.65 V to 5.5 V. The A port and B port are designed to track  $V_{CCA}$  and  $V_{CCB}$ , respectively allowing for low-voltage bidirectional translation between any of the 1.8-V, 2.5-V, 3.3-V and 5-V voltage nodes. The recommendation is to first power-up the input supply rail to help avoid internal floating while the output supply rail ramps up. However, both power-supply rails can be ramped up simultaneously.

## 11 Layout

### 11.1 Layout Guidelines

To ensure reliability of the device, the following common printed-circuit board layout guidelines are recommended:

- Bypass capacitors should be used on power supplies.
- Short trace lengths should be used to avoid excessive loading.
- Placing pads on the signal paths for loading capacitors or pullup resistors to help adjust rise and fall times of signals depends on the system requirements

### 11.2 Layout Example

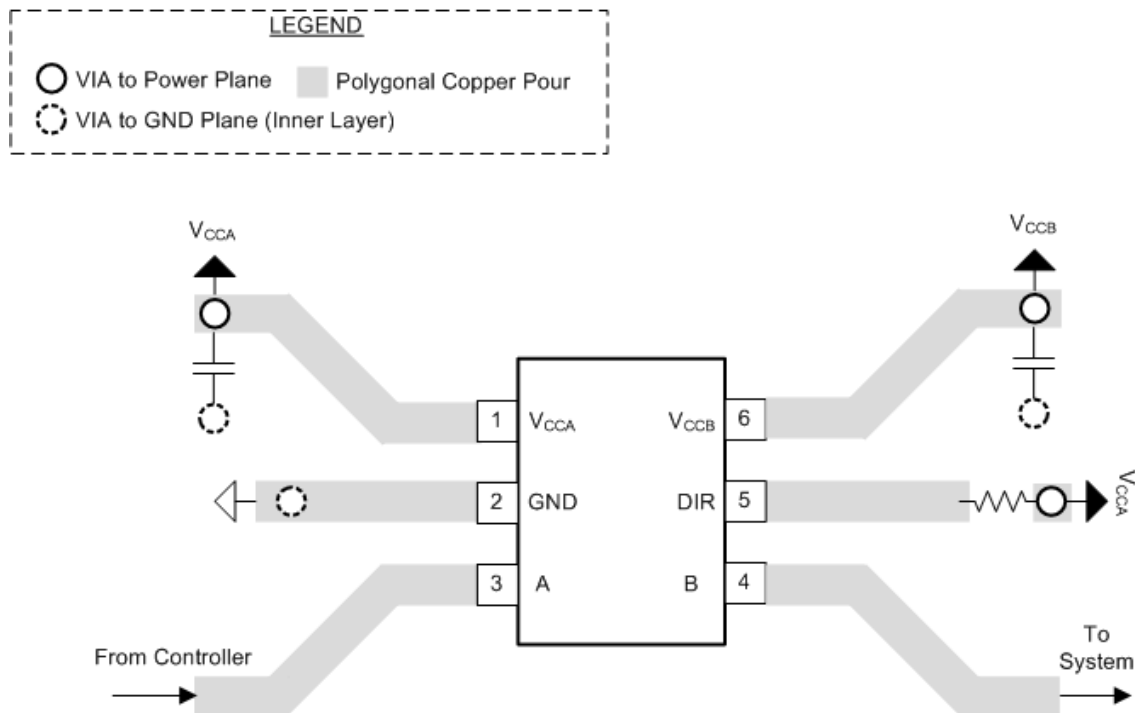

Figure 11-1. Layout Example

## 12 Device and Documentation Support

### 12.1 Documentation Support

#### 12.1.1 Related Documentation

For related documentation see the following:

- Texas Instruments, [Implications of Slow or Floating CMOS Inputs](#)

### 12.2 Receiving Notification of Documentation Updates

To receive notification of documentation updates, navigate to the device product folder on [ti.com](#). Click on *Subscribe to updates* to register and receive a weekly digest of any product information that has changed. For change details, review the revision history included in any revised document.

### 12.3 Support Resources

[TI E2E™ support forums](#) are an engineer's go-to source for fast, verified answers and design help — straight from the experts. Search existing answers or ask your own question to get the quick design help you need.

Linked content is provided "AS IS" by the respective contributors. They do not constitute TI specifications and do not necessarily reflect TI's views; see TI's [Terms of Use](#).

### 12.4 Trademarks

NanoFree™ is a trademark of Texas Instruments.

TI E2E™ is a trademark of Texas Instruments.

All trademarks are the property of their respective owners.

### 12.5 Electrostatic Discharge Caution



This integrated circuit can be damaged by ESD. Texas Instruments recommends that all integrated circuits be handled with appropriate precautions. Failure to observe proper handling and installation procedures can cause damage.

ESD damage can range from subtle performance degradation to complete device failure. Precision integrated circuits may be more susceptible to damage because very small parametric changes could cause the device not to meet its published specifications.

### 12.6 Glossary

[TI Glossary](#) This glossary lists and explains terms, acronyms, and definitions.

## 13 Mechanical, Packaging, and Orderable Information

The following pages include mechanical, packaging, and orderable information. This information is the most current data available for the designated devices. This data is subject to change without notice and revision of this document. For browser-based versions of this data sheet, refer to the left-hand navigation.

## PACKAGING INFORMATION

Orderable Device	Status (1)	Package Type	Package Drawing	Package Pins	Package Qty	Eco Plan (2)	Lead finish/ Ball material (6)	MSL Peak Temp (3)	Op Temp (°C)	Device Marking (4/5)	Samples
SN74LVC1T45DBVR	ACTIVE	SOT-23	DBV	6	3000	RoHS & Green	NIPDAU	Level-1-260C-UNLIM	-40 to 85	(CT15, CT1F, CT1R)	Samples
SN74LVC1T45DBVRE4	ACTIVE	SOT-23	DBV	6	3000	RoHS & Green	NIPDAU	Level-1-260C-UNLIM	-40 to 85	(CT15, CT1F, CT1R)	Samples
SN74LVC1T45DBVRG4	ACTIVE	SOT-23	DBV	6	3000	RoHS & Green	NIPDAU	Level-1-260C-UNLIM	-40 to 85	(CT15, CT1F, CT1R)	Samples
SN74LVC1T45DBVYT	ACTIVE	SOT-23	DBV	6	250	RoHS & Green	NIPDAU	Level-1-260C-UNLIM	-40 to 85	(CT15, CT1F, CT1R)	Samples
SN74LVC1T45DBVTG4	ACTIVE	SOT-23	DBV	6	250	RoHS & Green	NIPDAU	Level-1-260C-UNLIM	-40 to 85	(CT15, CT1F, CT1R)	Samples
SN74LVC1T45DCKR	ACTIVE	SC70	DCK	6	3000	RoHS & Green	NIPDAU   SN	Level-1-260C-UNLIM	-40 to 85	(TA5, TAF, TAR)	Samples
SN74LVC1T45DCKRE4	ACTIVE	SC70	DCK	6	3000	RoHS & Green	SN	Level-1-260C-UNLIM	-40 to 85	(TA5, TAF, TAR)	Samples
SN74LVC1T45DCKRG4	ACTIVE	SC70	DCK	6	3000	RoHS & Green	SN	Level-1-260C-UNLIM	-40 to 85	(TA5, TAF, TAR)	Samples
SN74LVC1T45DCKT	ACTIVE	SC70	DCK	6	250	RoHS & Green	NIPDAU   SN	Level-1-260C-UNLIM	-40 to 85	(TA5, TAF, TAR)	Samples
SN74LVC1T45DCKTE4	ACTIVE	SC70	DCK	6	250	RoHS & Green	SN	Level-1-260C-UNLIM	-40 to 85	(TA5, TAF, TAR)	Samples
SN74LVC1T45DCKTG4	ACTIVE	SC70	DCK	6	250	RoHS & Green	SN	Level-1-260C-UNLIM	-40 to 85	(TA5, TAF, TAR)	Samples
SN74LVC1T45DPKR	ACTIVE	USON	DPK	6	5000	RoHS & Green	NIPDAU	Level-1-260C-UNLIM	-40 to 85	TA7	Samples
SN74LVC1T45DRLR	ACTIVE	SOT-5X3	DRL	6	4000	RoHS & Green	NIPDAU   NIPDAUAG	Level-1-260C-UNLIM	-40 to 85	(1JX, TA7, TAR)	Samples
SN74LVC1T45DRLRG4	ACTIVE	SOT-5X3	DRL	6	4000	RoHS & Green	NIPDAU	Level-1-260C-UNLIM	-40 to 85	(1JX, TA7, TAR)	Samples
SN74LVC1T45YZPR	ACTIVE	DSBGA	YZP	6	3000	RoHS & Green	SNAGCU	Level-1-260C-UNLIM	-40 to 85	(TA2, TA7, TAN)	Samples

(1) The marketing status values are defined as follows:

**ACTIVE:** Product device recommended for new designs.

**LIFEBUY:** TI has announced that the device will be discontinued, and a lifetime-buy period is in effect.

**NRND:** Not recommended for new designs. Device is in production to support existing customers, but TI does not recommend using this part in a new design.

**PREVIEW:** Device has been announced but is not in production. Samples may or may not be available.

**OBSOLETE:** TI has discontinued the production of the device.

(2) **RoHS:** TI defines "RoHS" to mean semiconductor products that are compliant with the current EU RoHS requirements for all 10 RoHS substances, including the requirement that RoHS substance do not exceed 0.1% by weight in homogeneous materials. Where designed to be soldered at high temperatures, "RoHS" products are suitable for use in specified lead-free processes. TI may reference these types of products as "Pb-Free".

**RoHS Exempt:** TI defines "RoHS Exempt" to mean products that contain lead but are compliant with EU RoHS pursuant to a specific EU RoHS exemption.

**Green:** TI defines "Green" to mean the content of Chlorine (Cl) and Bromine (Br) based flame retardants meet JS709B low halogen requirements of  $\leq 1000$ ppm threshold. Antimony trioxide based flame retardants must also meet the  $\leq 1000$ ppm threshold requirement.

(3) **MSL, Peak Temp.** - The Moisture Sensitivity Level rating according to the JEDEC industry standard classifications, and peak solder temperature.

(4) There may be additional marking, which relates to the logo, the lot trace code information, or the environmental category on the device.

(5) Multiple Device Markings will be inside parentheses. Only one Device Marking contained in parentheses and separated by a "~" will appear on a device. If a line is indented then it is a continuation of the previous line and the two combined represent the entire Device Marking for that device.

(6) **Lead finish/Ball material - Orderable Devices** may have multiple material finish options. Finish options are separated by a vertical ruled line. Lead finish/Ball material values may wrap to two lines if the finish value exceeds the maximum column width.

**Important Information and Disclaimer:** The information provided on this page represents TI's knowledge and belief as of the date that it is provided. TI bases its knowledge and belief on information provided by third parties, and makes no representation or warranty as to the accuracy of such information. Efforts are underway to better integrate information from third parties. TI has taken and continues to take reasonable steps to provide representative and accurate information but may not have conducted destructive testing or chemical analysis on incoming materials and chemicals. TI and TI suppliers consider certain information to be proprietary, and thus CAS numbers and other limited information may not be available for release.

In no event shall TI's liability arising out of such information exceed the total purchase price of the TI part(s) at issue in this document sold by TI to Customer on an annual basis.

**OTHER QUALIFIED VERSIONS OF SN74LVC1T45 :**

- Automotive : [SN74LVC1T45-Q1](#)
- Enhanced Product : [SN74LVC1T45-EP](#)

**NOTE:** Qualified Version Definitions:

- Automotive - Q100 devices qualified for high-reliability automotive applications targeting zero defects
- Enhanced Product - Supports Defense, Aerospace and Medical Applications

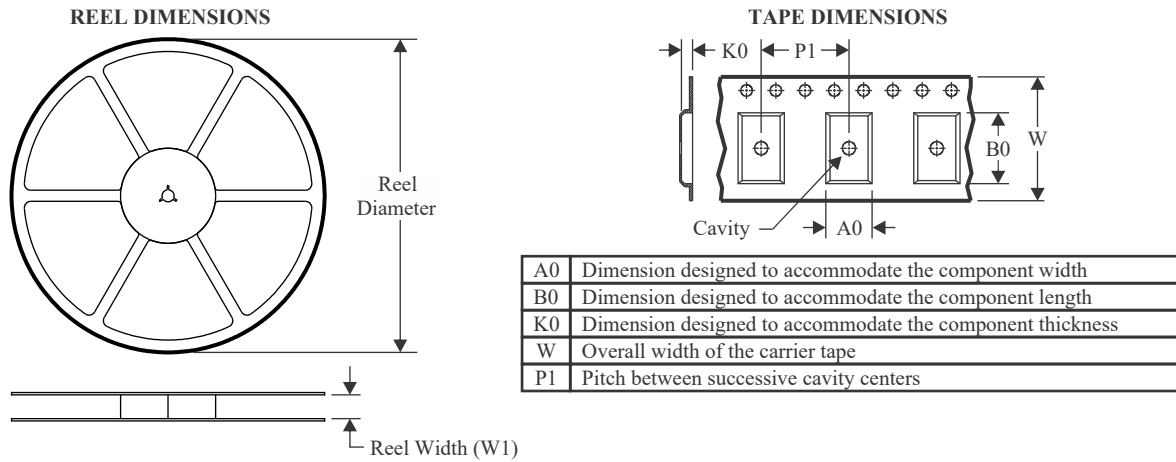
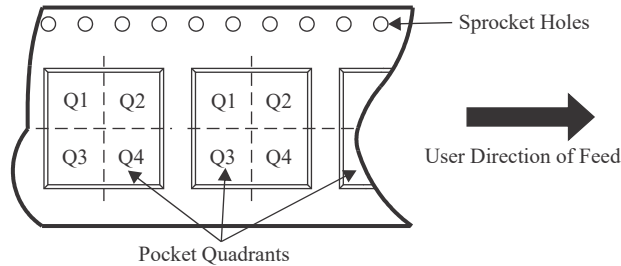
**TAPE AND REEL INFORMATION**

**QUADRANT ASSIGNMENTS FOR PIN 1 ORIENTATION IN TAPE**

\*All dimensions are nominal

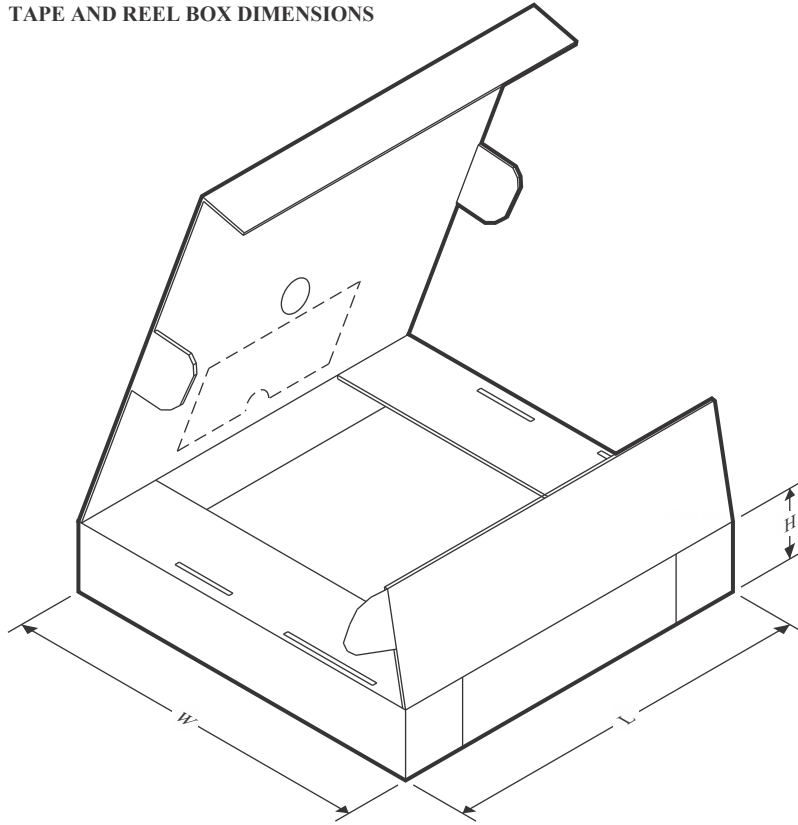
Device	Package Type	Package Drawing	Pins	SPQ	Reel Diameter (mm)	Reel Width W1 (mm)	A0 (mm)	B0 (mm)	K0 (mm)	P1 (mm)	W (mm)	Pin1 Quadrant
SN74LVC1T45DBVR	SOT-23	DBV	6	3000	180.0	8.4	3.23	3.17	1.37	4.0	8.0	Q3
SN74LVC1T45DBVR	SOT-23	DBV	6	3000	178.0	9.0	3.23	3.17	1.37	4.0	8.0	Q3
SN74LVC1T45DBVT	SOT-23	DBV	6	250	178.0	9.2	3.3	3.23	1.55	4.0	8.0	Q3
SN74LVC1T45DBVT	SOT-23	DBV	6	250	178.0	9.0	3.23	3.17	1.37	4.0	8.0	Q3
SN74LVC1T45DBVT	SOT-23	DBV	6	250	180.0	8.4	3.23	3.17	1.37	4.0	8.0	Q3
SN74LVC1T45DCKR	SC70	DCK	6	3000	180.0	8.4	2.3	2.5	1.2	4.0	8.0	Q3
SN74LVC1T45DCKT	SC70	DCK	6	250	180.0	8.4	2.41	2.41	1.2	4.0	8.0	Q3
SN74LVC1T45DCKT	SC70	DCK	6	250	178.0	9.0	2.4	2.5	1.2	4.0	8.0	Q3
SN74LVC1T45DCKT	SC70	DCK	6	250	178.0	9.2	2.4	2.4	1.22	4.0	8.0	Q3
SN74LVC1T45DPKR	USON	DPK	6	5000	180.0	9.5	1.75	1.75	0.7	4.0	8.0	Q2
SN74LVC1T45DRLR	SOT-5X3	DRL	6	4000	180.0	8.4	2.0	1.8	0.75	4.0	8.0	Q3
SN74LVC1T45YZPR	DSBGA	YZP	6	3000	178.0	9.2	1.02	1.52	0.63	4.0	8.0	Q1

**TAPE AND REEL BOX DIMENSIONS**

\*All dimensions are nominal

Device	Package Type	Package Drawing	Pins	SPQ	Length (mm)	Width (mm)	Height (mm)
SN74LVC1T45DBVR	SOT-23	DBV	6	3000	202.0	201.0	28.0
SN74LVC1T45DBVR	SOT-23	DBV	6	3000	180.0	180.0	18.0
SN74LVC1T45DBVT	SOT-23	DBV	6	250	180.0	180.0	18.0
SN74LVC1T45DBVT	SOT-23	DBV	6	250	180.0	180.0	18.0
SN74LVC1T45DBVT	SOT-23	DBV	6	250	202.0	201.0	28.0
SN74LVC1T45DCKR	SC70	DCK	6	3000	210.0	185.0	35.0
SN74LVC1T45DCKT	SC70	DCK	6	250	202.0	201.0	28.0
SN74LVC1T45DCKT	SC70	DCK	6	250	180.0	180.0	18.0
SN74LVC1T45DCKT	SC70	DCK	6	250	180.0	180.0	18.0
SN74LVC1T45DPKR	USON	DPK	6	5000	184.0	184.0	19.0
SN74LVC1T45DRLR	SOT-5X3	DRL	6	4000	210.0	185.0	35.0
SN74LVC1T45YZPR	DSBGA	YZP	6	3000	220.0	220.0	35.0



# DRL0006A

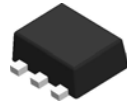

# PACKAGE OUTLINE

## SOT - 0.6 mm max height

PLASTIC SMALL OUTLINE

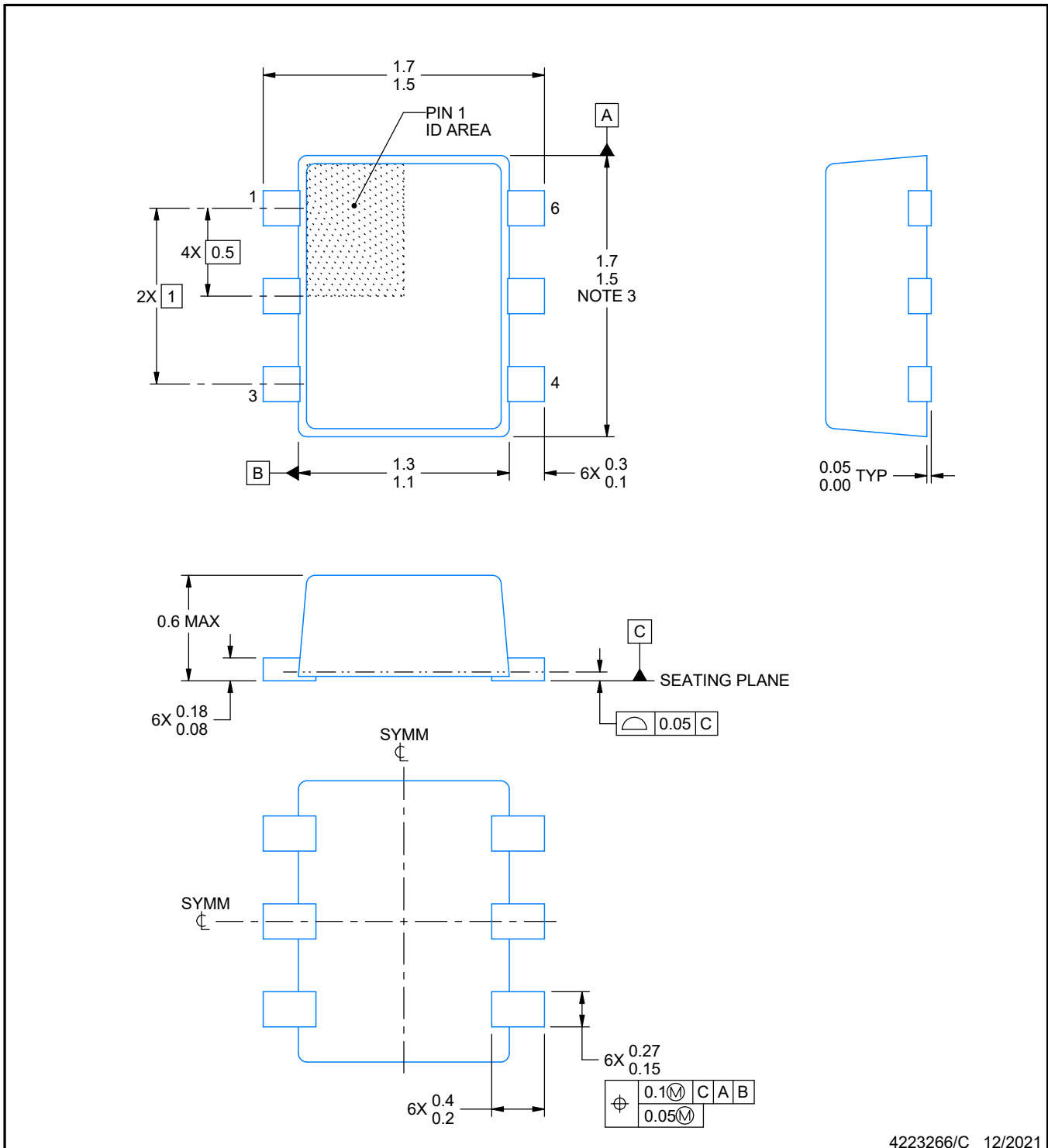

4223266/C 12/2021

### NOTES:

1. All linear dimensions are in millimeters. Any dimensions in parenthesis are for reference only. Dimensioning and tolerancing per ASME Y14.5M.
2. This drawing is subject to change without notice.
3. This dimension does not include mold flash, protrusions, or gate burrs. Mold flash, protrusions, or gate burrs shall not exceed 0.15 mm per side.
4. Reference JEDEC registration MO-293 Variation UAAD

# EXAMPLE BOARD LAYOUT

DRL0006A

SOT - 0.6 mm max height

PLASTIC SMALL OUTLINE

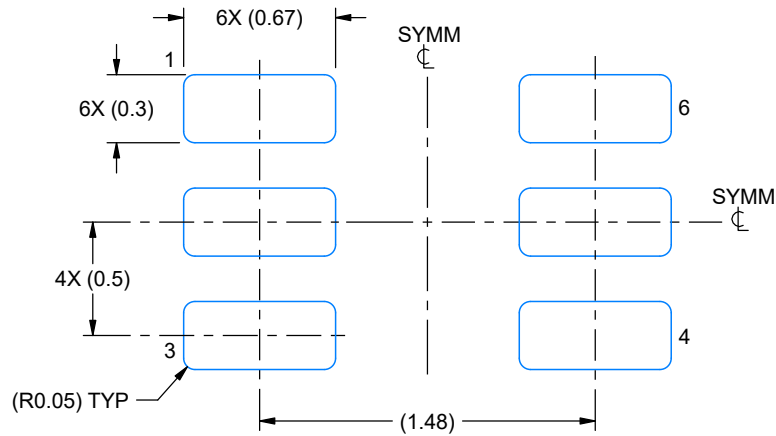

LAND PATTERN EXAMPLE  
SCALE:30X

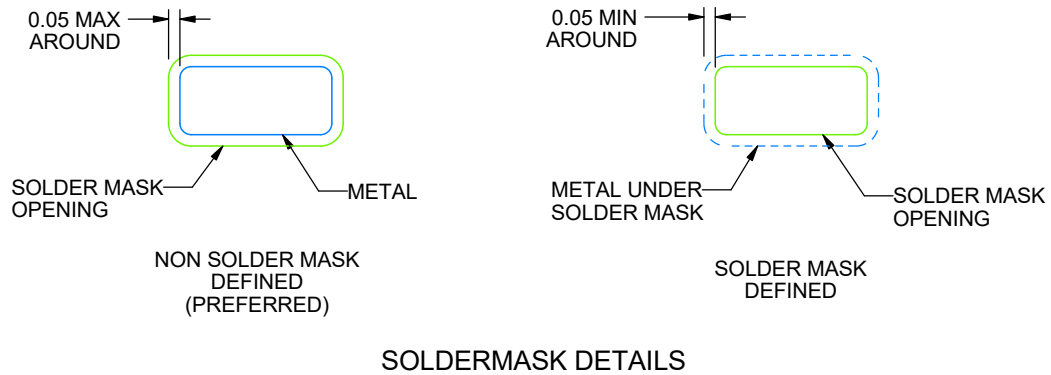

SOLDERMASK DETAILS

4223266/C 12/2021

NOTES: (continued)

5. Publication IPC-7351 may have alternate designs.
6. Solder mask tolerances between and around signal pads can vary based on board fabrication site.
7. Land pattern design aligns to IPC-610, Bottom Termination Component (BTC) solder joint inspection criteria.

# EXAMPLE STENCIL DESIGN

DRL0006A

SOT - 0.6 mm max height

PLASTIC SMALL OUTLINE

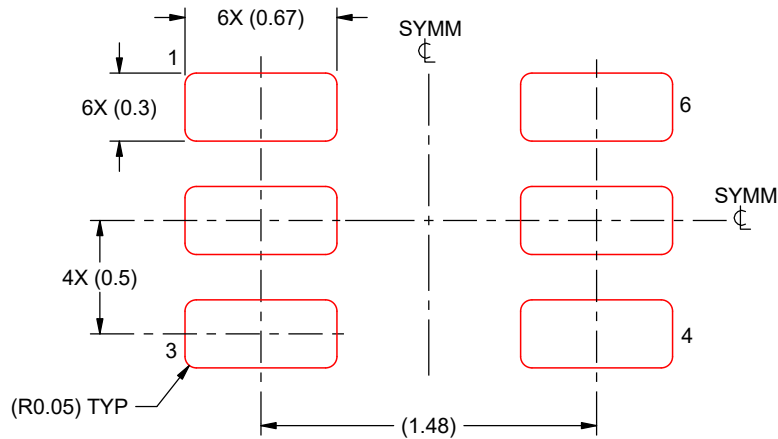

SOLDER PASTE EXAMPLE  
BASED ON 0.1 mm THICK STENCIL  
SCALE:30X

4223266/C 12/2021

NOTES: (continued)

8. Laser cutting apertures with trapezoidal walls and rounded corners may offer better paste release. IPC-7525 may have alternate design recommendations.
9. Board assembly site may have different recommendations for stencil design.

DCK (R-PDSO-G6)

PLASTIC SMALL-OUTLINE PACKAGE

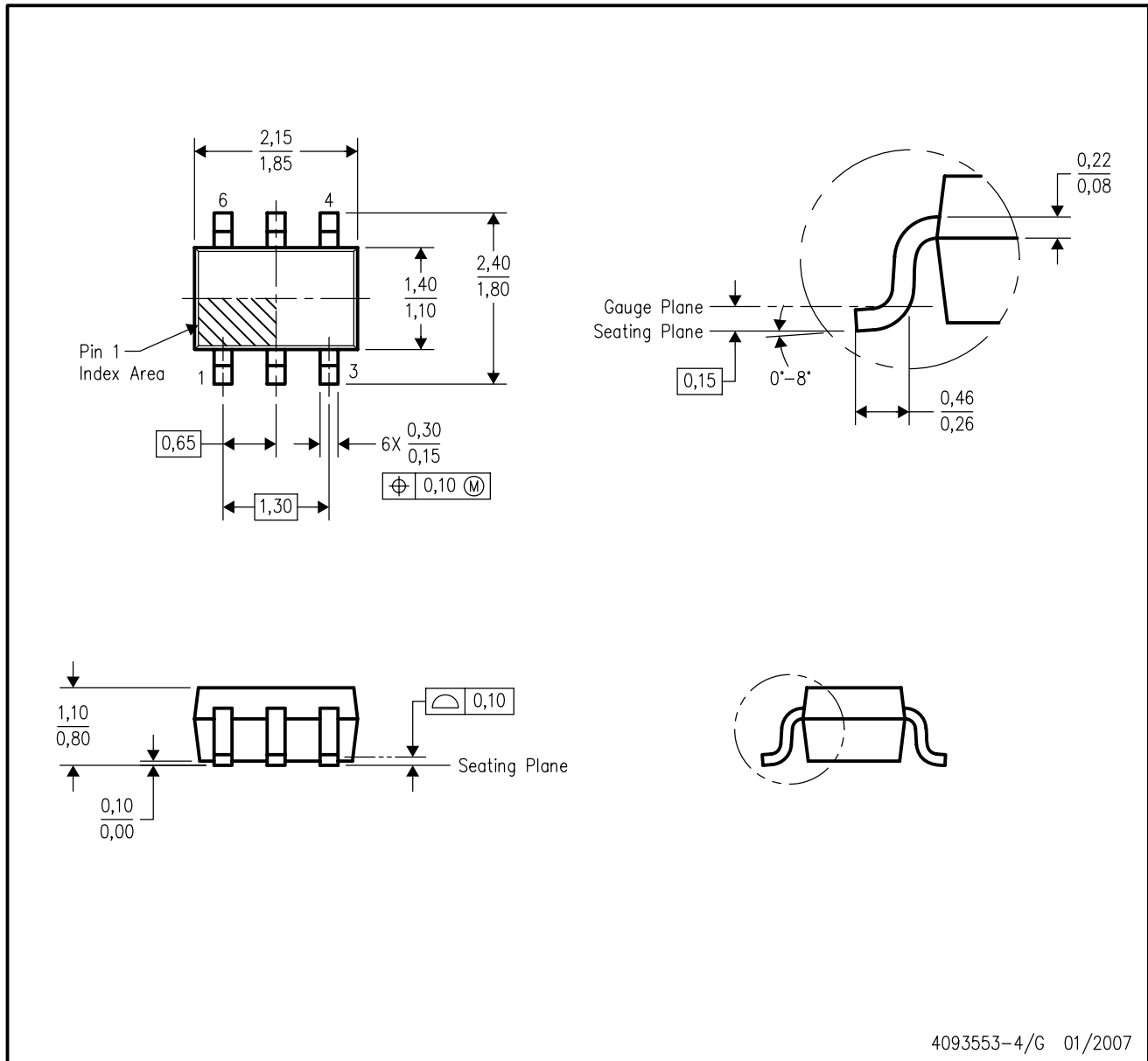

- NOTES:
- A. All linear dimensions are in millimeters.
  - B. This drawing is subject to change without notice.
  - C. Body dimensions do not include mold flash or protrusion. Mold flash and protrusion shall not exceed 0.15 per side.
  - D. Falls within JEDEC MO-203 variation AB.

DCK (R-PDSO-G6)

PLASTIC SMALL OUTLINE

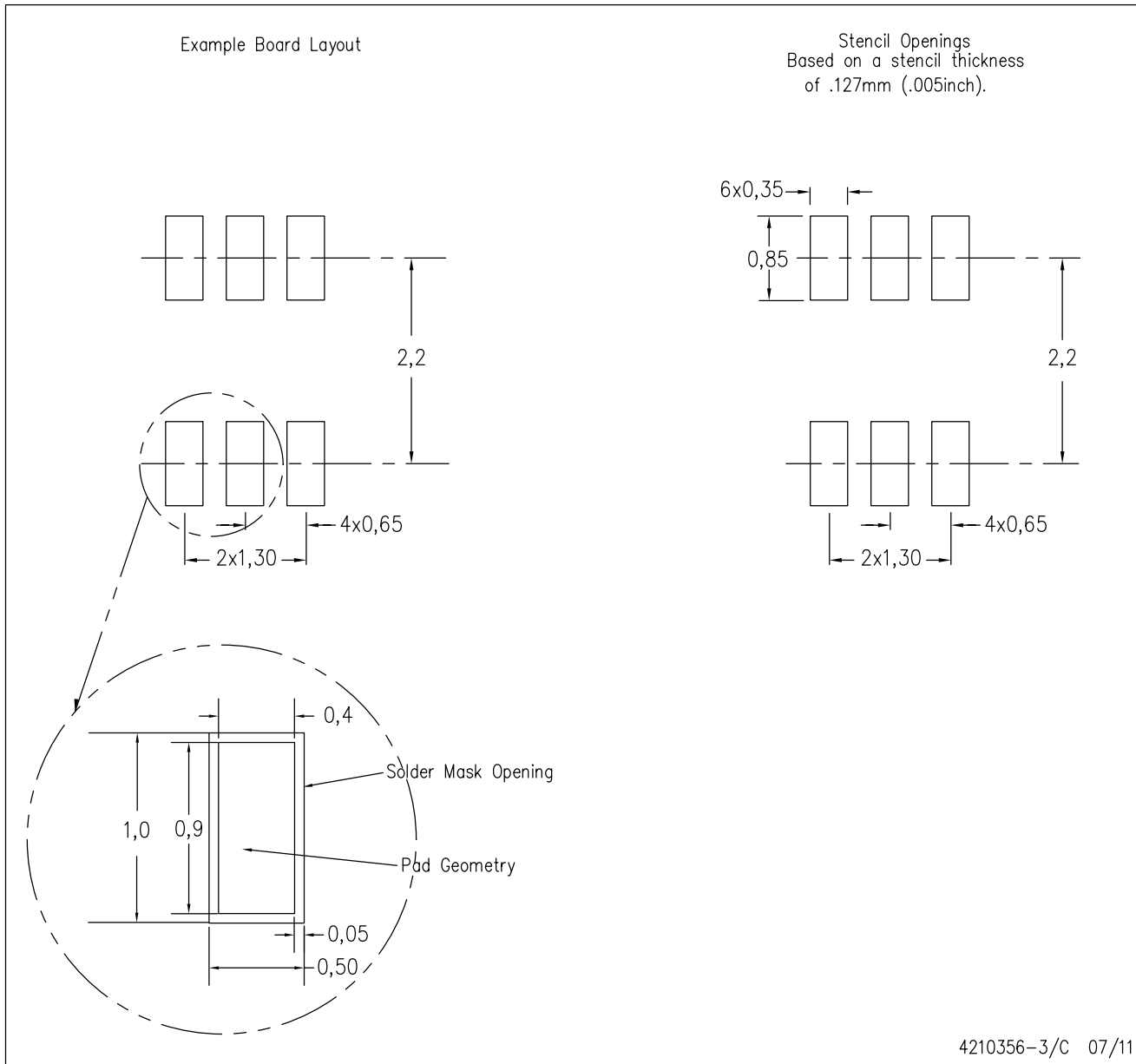

- NOTES:
- A. All linear dimensions are in millimeters.
  - B. This drawing is subject to change without notice.
  - C. Customers should place a note on the circuit board fabrication drawing not to alter the center solder mask defined pad.
  - D. Publication IPC-7351 is recommended for alternate designs.
  - E. Laser cutting apertures with trapezoidal walls and also rounding corners will offer better paste release. Customers should contact their board assembly site for stencil design recommendations. Example stencil design based on a 50% volumetric metal load solder paste. Refer to IPC-7525 for other stencil recommendations.

# DBV0006A



# PACKAGE OUTLINE

## SOT-23 - 1.45 mm max height

SMALL OUTLINE TRANSISTOR

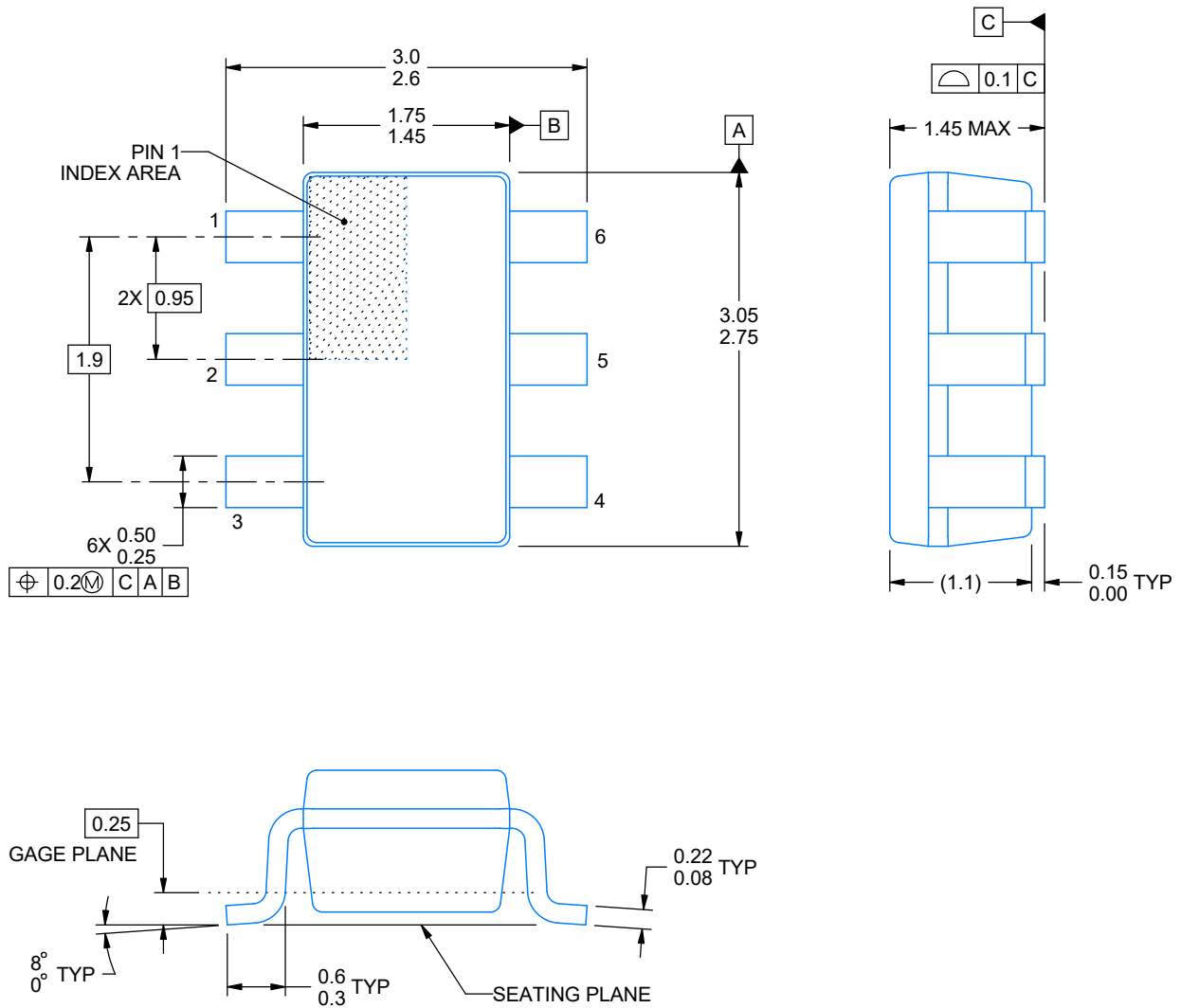

4214840/C 06/2021

### NOTES:

1. All linear dimensions are in millimeters. Any dimensions in parenthesis are for reference only. Dimensioning and tolerancing per ASME Y14.5M.
2. This drawing is subject to change without notice.
3. Body dimensions do not include mold flash or protrusion. Mold flash and protrusion shall not exceed 0.25 per side.
4. Leads 1,2,3 may be wider than leads 4,5,6 for package orientation.
5. Reference JEDEC MO-178.

# EXAMPLE BOARD LAYOUT

DBV0006A

SOT-23 - 1.45 mm max height

SMALL OUTLINE TRANSISTOR

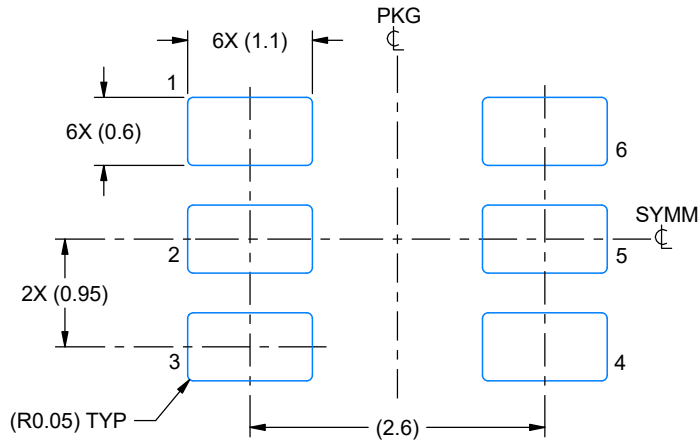

LAND PATTERN EXAMPLE  
EXPOSED METAL SHOWN  
SCALE:15X

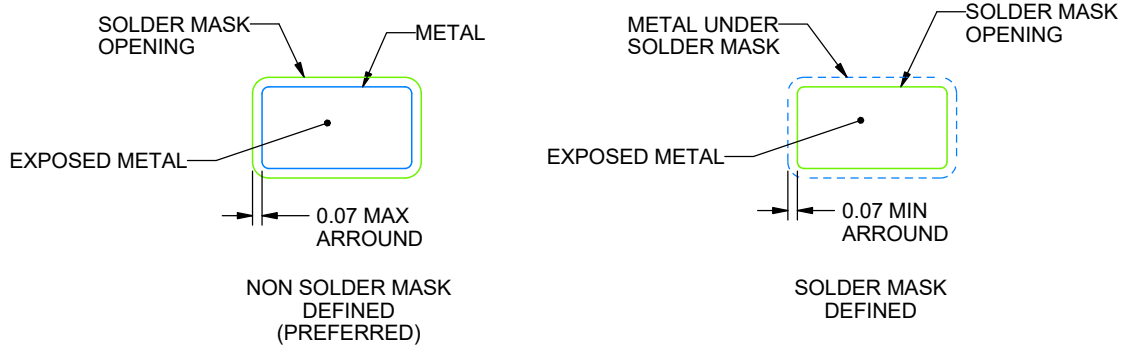

SOLDER MASK DETAILS

4214840/C 06/2021

NOTES: (continued)

6. Publication IPC-7351 may have alternate designs.

7. Solder mask tolerances between and around signal pads can vary based on board fabrication site.

# EXAMPLE STENCIL DESIGN

DBV0006A

SOT-23 - 1.45 mm max height

SMALL OUTLINE TRANSISTOR

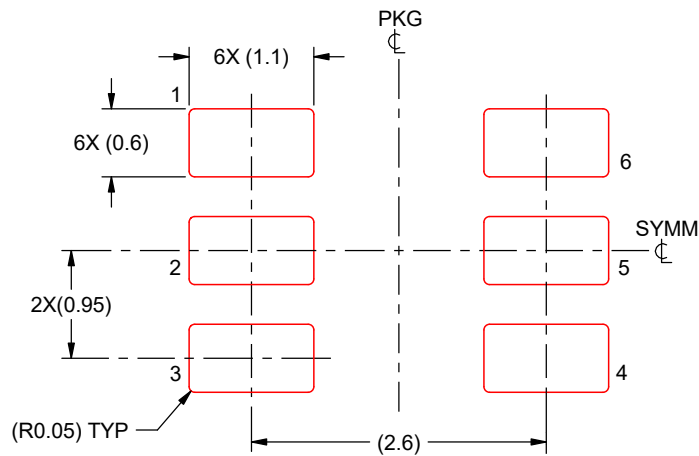

SOLDER PASTE EXAMPLE  
BASED ON 0.125 mm THICK STENCIL  
SCALE:15X

4214840/C 06/2021

NOTES: (continued)

8. Laser cutting apertures with trapezoidal walls and rounded corners may offer better paste release. IPC-7525 may have alternate design recommendations.
9. Board assembly site may have different recommendations for stencil design.



DPK (S-PUSON-N6)

PLASTIC SMALL OUTLINE NO-LEAD

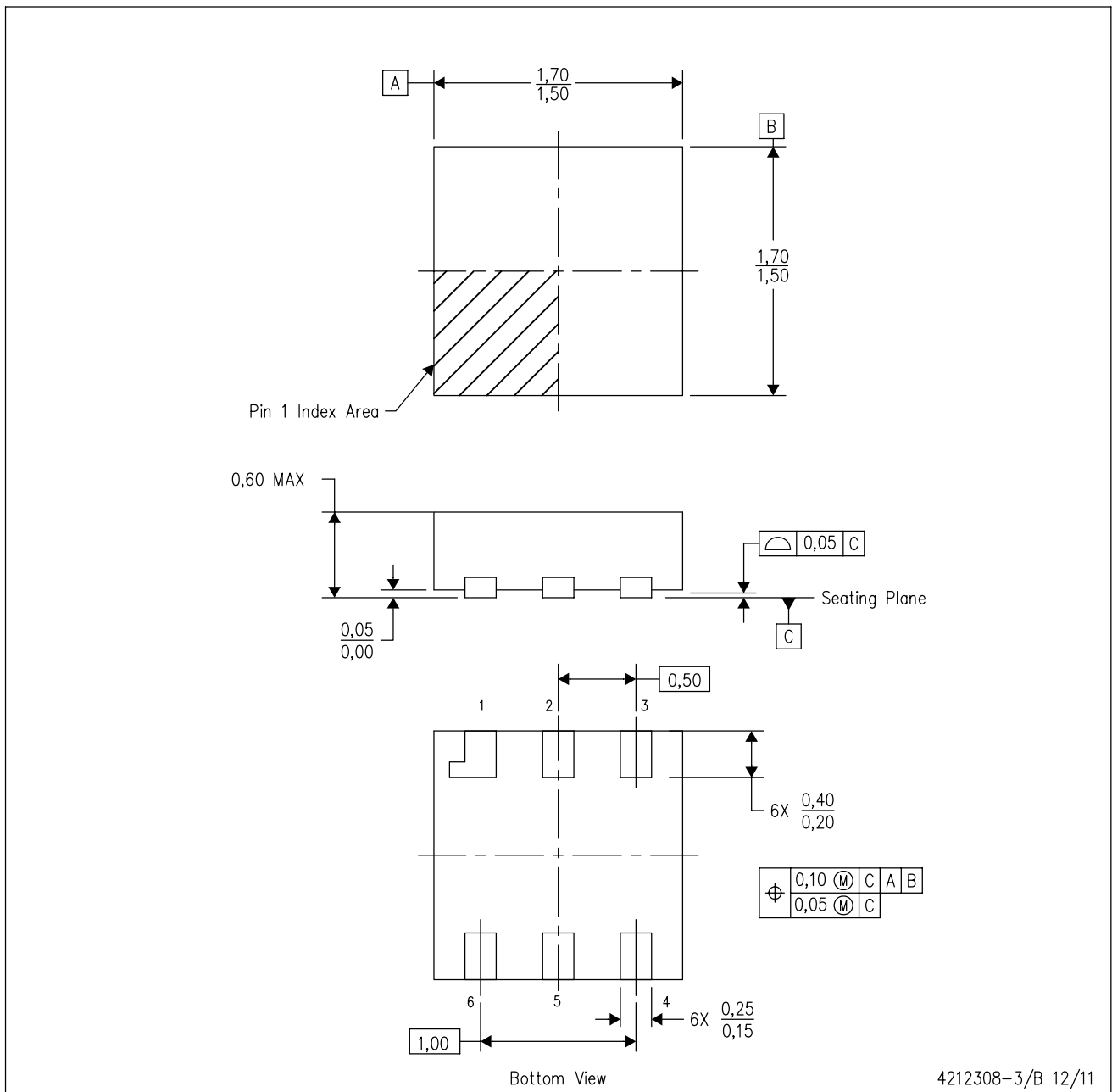

4212308-3/B 12/11

NOTES: A. All linear dimensions are in millimeters. Dimensioning and tolerancing per ASME Y14.5M-1994.  
 B. This drawing is subject to change without notice.

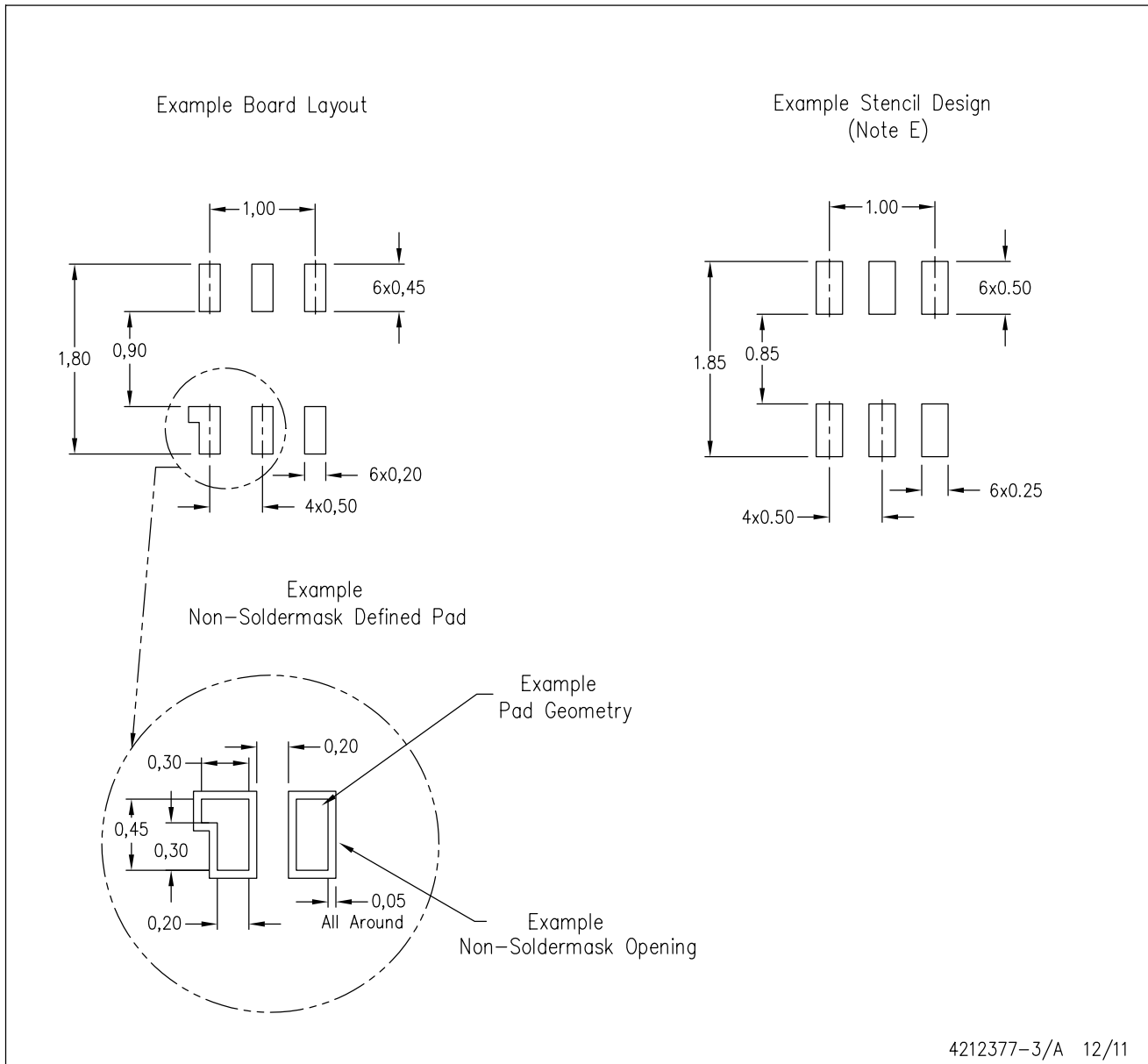

- NOTES:
- All linear dimensions are in millimeters.
  - This drawing is subject to change without notice.
  - Publication IPC-7351 is recommended for alternate designs.
  - Customers should contact their board fabrication site for minimum solder mask web tolerances between signal pads.
  - Maximum stencil thickness 0,127 mm (5 mils). All linear dimensions are in millimeters.
  - Laser cutting apertures with trapezoidal walls and also rounding corners will offer better paste release. Customers should contact their board assembly site for stencil design recommendations. Refer to IPC 7525 for stencil design considerations.
  - Side aperture dimensions over-print land for acceptable area ratio > 0.66. Customer may reduce side aperture dimensions if stencil manufacturing process allows for sufficient release at smaller opening.

YZP0006

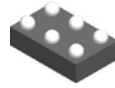

# PACKAGE OUTLINE

## DSBGA - 0.5 mm max height

DIE SIZE BALL GRID ARRAY

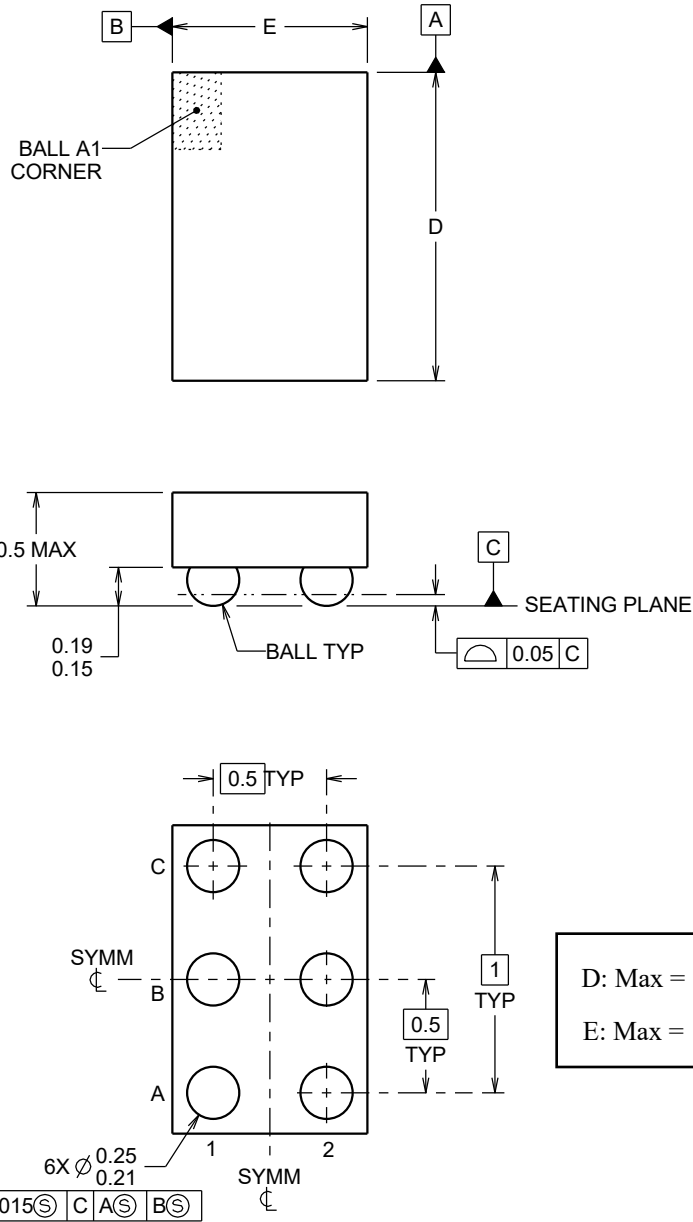

4219524/A 06/2014

NOTES:

NanoFree Is a trademark of Texas Instruments.

1. All linear dimensions are in millimeters. Any dimensions in parenthesis are for reference only. Dimensioning and tolerancing per ASME Y14.5M.
2. This drawing is subject to change without notice.
3. NanoFree™ package configuration.

# EXAMPLE BOARD LAYOUT

YZP0006

DSBGA - 0.5 mm max height

DIE SIZE BALL GRID ARRAY

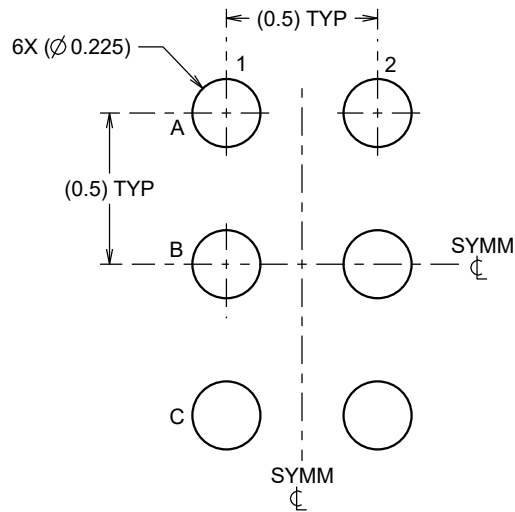

LAND PATTERN EXAMPLE  
SCALE:40X

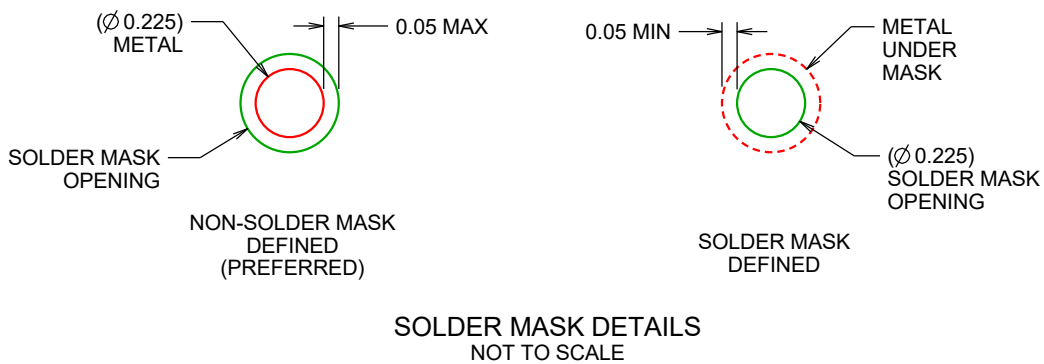

4219524/A 06/2014

NOTES: (continued)

- Final dimensions may vary due to manufacturing tolerance considerations and also routing constraints. For more information, see Texas Instruments literature number SBVA017 ([www.ti.com/lit/sbva017](http://www.ti.com/lit/sbva017)).

# EXAMPLE STENCIL DESIGN

YZP0006

DSBGA - 0.5 mm max height

DIE SIZE BALL GRID ARRAY

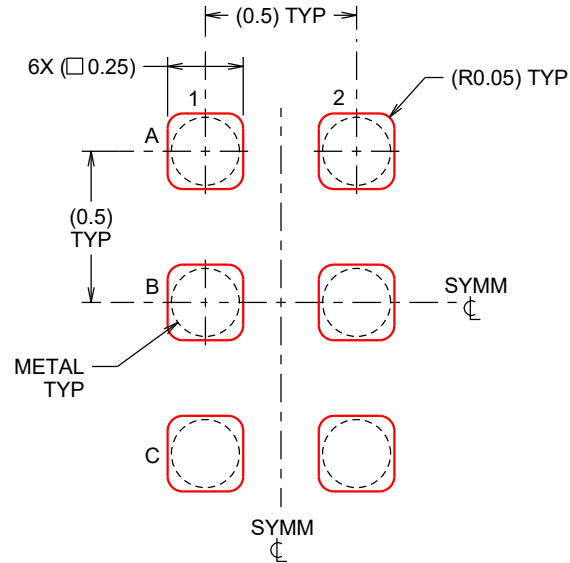

SOLDER PASTE EXAMPLE  
BASED ON 0.1 mm THICK STENCIL  
SCALE:40X

4219524/A 06/2014

NOTES: (continued)

5. Laser cutting apertures with trapezoidal walls and rounded corners may offer better paste release.

## IMPORTANT NOTICE AND DISCLAIMER

TI PROVIDES TECHNICAL AND RELIABILITY DATA (INCLUDING DATA SHEETS), DESIGN RESOURCES (INCLUDING REFERENCE DESIGNS), APPLICATION OR OTHER DESIGN ADVICE, WEB TOOLS, SAFETY INFORMATION, AND OTHER RESOURCES "AS IS" AND WITH ALL FAULTS, AND DISCLAIMS ALL WARRANTIES, EXPRESS AND IMPLIED, INCLUDING WITHOUT LIMITATION ANY IMPLIED WARRANTIES OF MERCHANTABILITY, FITNESS FOR A PARTICULAR PURPOSE OR NON-INFRINGEMENT OF THIRD PARTY INTELLECTUAL PROPERTY RIGHTS.

These resources are intended for skilled developers designing with TI products. You are solely responsible for (1) selecting the appropriate TI products for your application, (2) designing, validating and testing your application, and (3) ensuring your application meets applicable standards, and any other safety, security, regulatory or other requirements.

These resources are subject to change without notice. TI grants you permission to use these resources only for development of an application that uses the TI products described in the resource. Other reproduction and display of these resources is prohibited. No license is granted to any other TI intellectual property right or to any third party intellectual property right. TI disclaims responsibility for, and you will fully indemnify TI and its representatives against, any claims, damages, costs, losses, and liabilities arising out of your use of these resources.

TI's products are provided subject to [TI's Terms of Sale](#) or other applicable terms available either on [ti.com](https://www.ti.com) or provided in conjunction with such TI products. TI's provision of these resources does not expand or otherwise alter TI's applicable warranties or warranty disclaimers for TI products.

TI objects to and rejects any additional or different terms you may have proposed.

Mailing Address: Texas Instruments, Post Office Box 655303, Dallas, Texas 75265  
Copyright © 2023, Texas Instruments Incorporated